

No	Alt No	Direction/Street/City
8		AIRPORT RD, LINCOLN

OWNERSHIP

Owner 1: UNITED STATES OF AMERICA

Street 1: 174 LIBERTY ST

Twn/City: CONCORD

St/Prov: MA Cntry Own Occ: Y

Postal: 01742 Type:

ACTIVITY INFORMATION

Date	Result	By	Name
3/28/1998	MEAS/EXT INS	602	D TUCKER
2/13/1996	MEAS+INSPCTD	606	J SMITH

PROPERTY FACTORS

Item	Code	Descip	%	Item	Code	Descip
Z	R1	Residential	100	U	A	SEPTIC

Exmpt:

CONDO INFORMATION

Location: Phys Cond: Average 32.20%
 Unit #: Functional: %
 Floor: 1ST FLOOR Economic: %
 % Own: Special: %
 Name: Override: %

IN PROCESS APPRAISAL SUMMARY

Use Code	Building Value	Yard Items	Land Size	Land Value	Total Value
900	207,900	600	1.000	397,800	606,300
Total Card	207,900	600	1.000	397,800	606,300
Total Parcel	207,900	600	1.000	397,800	606,300

Source: Market Adj Cost Total Assmnt per SQ unit /Card: 213.79 /Parcel: 213.79

PREVIOUS ASSESSMENT

Tax Yr	Use	Building Value	Yard Items	Land Size	Land Value	Total Value	Total Assessed
2009	900	235,800	600	1.	296,600	533,000	533,000
2008	900	229,300	500	1.	311,700	541,500	541,500

SALES INFORMATION

Grantor	Legal Ref	Type	Date	Nal Desc	Sale Price	V	Tst	Verif	Assoc PCL Value
STOUT JOSEPHINE	29544-555		12/17/1998	INVOLVED GOV	373180	No	No		
GARY FONSECA	12275-10		8/25/1972	FAMILY		0	No	No	

SPEC FEATURES/YARD ITEMS

Code	Description	A	Y/S	Qty	Size/Dim	Qual	Con	Year	Unit Price	D/S	Dep	LUC	Fact	NB Fa	Appr Value	JCod	JFact	Ass'd Value
2	SHED/FR		Y	1	144	A	AV	1948	15.00	T	70	900		EV	600			600

More: N Total Yard Items: 600 Total Special Features: Total: 600

LAND SECTION

Code	Description	Fact	Units	Depth/PrUni	Unit Type	Land Type	Factor	Base	Price	Adj	NBC	N.INF	N.Mod	Inf1	%	Inf2	%	Inf3	%	Appraised	Alt Clas	%	Spec	J	Fact	Use Value	Notes
900	US GOVT		43560		SQUARE FE	PRIME SITE		0	5.76	1.586	EV									397,832						397,800	

Total AC/HA: 1.00000 Total SF/SM: 43560.00 Parcel LUC: 900 US GOVT Prime NB Desc RES AVGD Total: 397,832 Spl Credit Total: 397,800 More: N

EXTERIOR INFORMATION

Type: COLONIAL
 Sty Ht: 2A - 2A
 (Liv) Units: 1 Total: 1
 Foundation: CONCRETE
 Frame: WOOD
 Prime Wall: WOOD SHING
 Sec Wall: %
 Roof Struct: GABLE
 Roof Cover: ASPHALT
 Color:
 View /Desir:

GENERAL INFORMATION

Grade: AVERAGE
 Year Blt: 1948 Eff Yr Blt:
 Alt LUC: Alt %:
 Jurisdic: Fact:
 Const Mod:
 Lump Sum Adj:

Town Of Lincoln

ParcelID: 830
 Pat Acct: 2061

OTHER FEATURES

Kits: 1 Rating: AVERAGE
 A Kits: Rating:
 Frpl: 2 Rating: AVERAGE
 WSFlue: Rating:

REMODELING

Exterior:
 Interior:
 Additions:
 Kitchen:
 Baths:
 Plumbing:
 Electric:
 Heating:
 General:

INTERIOR INFORMATION

Avg Ht/FL: STD
 Prim Int Wal: PLASTER
 Sec Int Wall: %
 Partition: TYPICAL
 Prim Floors: HARDWOOD
 Sec Floors: %
 Bsmnt Flr:
 Bsmnt Gar:
 Electric: TYPICAL
 Insulation: TYPICAL
 Int vs Ext: S
 Heat Fuel: OIL
 Heat Type: FORCED H/W
 # Heat Sys: 1
 % Heated: 100 % AC:
 Solar HW: NO Central Vac: NO
 % Com Wal: 0 % Sprinkled: 0

BATH FEATURES

Full Bath: 1 Rating: AVERAGE
 A Bath: Rating:
 3/4 Bath: Rating:
 A 3QBth: Rating:
 1/2 Bath: 1 Rating: AVERAGE
 A HBth: Rating:
 OthrFix: 1 Rating: AVERAGE

Print Date/Time
 10/09/09 19:21:06

TAX DISTRICT []

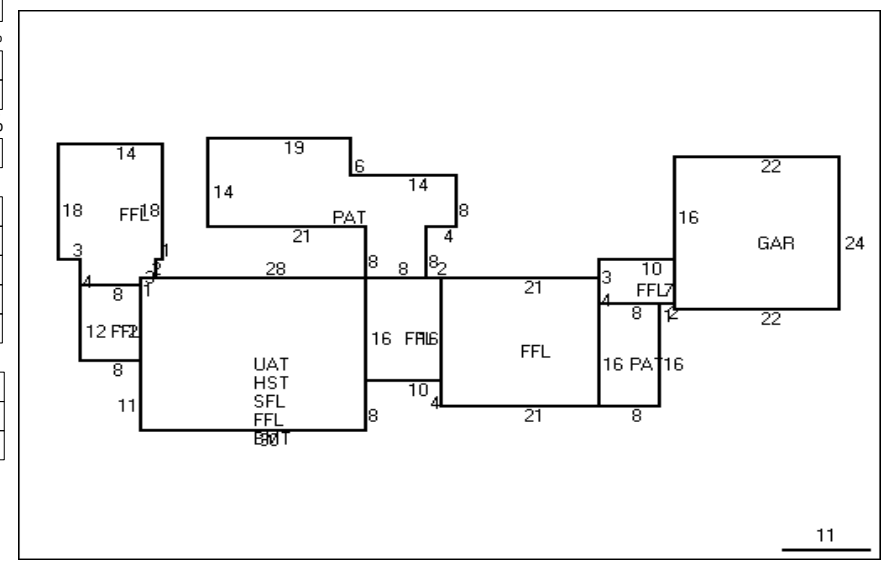

BUILDING PERMITS CARD 1 of 1 **TOTAL ASSESSED: 606,300**

Date	Number	Descip	Amount	C/O	Last Visit	Fed Code	F. Descip	Comment
5/27/1997	1191	RENOVATI	21,000	C	3/28/1998			
5/18/1994	236	GARAGE	22,000	C	12/7/1993			

SUB AREA

Code	Description	Area - SQ	Rate - AV	Undepr Value	
FFL	1ST FLOOR	1,756	78.460	137,782	
BMT	BASEMENT	720	19.620	14,123	
SFL	2ND FLOOR	720	78.460	56,494	
PAT	PATIO	570	7.000	3,990	
GAR	GARAGE	528	36.000	19,008	
HST	HALF STORY	360	78.460	28,247	
Net Sketched Area:		4,762	Total:		
Size Ad	2836.0000	Gross Area	5734	FinArea	2836

RES BREAKDOWN

No	Unit	RMS	BRS	FL
	1	8	3	

SUB AREA DETAIL

Sub Area	% Usbl	Descip	% Type	Qu	# Ten

CALC SUMMARY

Basic \$ / SQ: 80.00
 Size Adj.: 0.96156561
 Const Adj.: 1.01999998
 Adj \$ / SQ: 78.464
 Grade Factor: 1.00
 Other Features: 38500
 Neighborhood Inf: 1.00000000
 LUC Factor: 1.00
 Adj Total: 306619
 Depreciation: 98731
 Depreciated Total: 207888
 Juris. Factor
 Special Features: 0
 Final Total: 207900

COMMENTS

Legal Description
 180