



Patriot Properties Inc.

PROPERTY LOCATION

| No | Alt No | Direction/Street/City |
|----|--------|-----------------------|
| 8 | | HUNTLEY LN, LINCOLN |

OWNERSHIP

| | |
|-----------|---------------------|
| Owner 1: | CAPPUCCI THOMAS A |
| Owner 2: | CAPPUCCI BARBARA A |
| Owner 3: | |
| Street 1: | 8 HUNTLEY LN |
| Street 2: | |
| Twn/City: | LINCOLN |
| St/Prov: | MA Cntry Own Occ: Y |
| Postal: | 01773-5008 Type: |

PREVIOUS OWNER

| | |
|-----------|-------------------------|
| Owner 1: | CAPPUCCI TR - THOMAS A |
| Owner 2: | CAPPUCCI TR - BARBARA A |
| Street 1: | 8 HUNTLEY LN |
| Twn/City: | LINCOLN |
| St/Prov: | MA Cntry |
| Postal: | 01773-5008 |

NARRATIVE DESCRIPTION

This Parcel contains .91 ACRES of land mainly classified as ONE FAM with a(n) CAPE Building Built about 1979, Having Primarily CLAPBOARD Exterior and ASPHALT Roof Cover, with 1 Units, 2 Baths, 0 HalfBaths, 0 3/4 Baths, 8 Rooms, and 3 Bdrms.

OTHER ASSESSMENTS

| Code | Descrip/No | Amount | Com. Int |
|------|------------|--------|----------|
| | | | |

PROPERTY FACTORS

| Item | Code | Descp | % | Item | Code | Descp |
|------------|------|-------------|-----|---------|------|--------|
| Z | R1 | Residential | 100 | U | A | SEPTIC |
| o | | | | t | | |
| n | | | | l | | |
| Census: | | | | Exmpt | | |
| Flood Haz: | | | | | | |
| D | | | | Topo | | |
| s | | | | Street | 1 | PAVED |
| t | | | | Traffic | 4 | MEDIUM |

LAND SECTION (First 7 lines only)

| Use Code | Description | LUC Fact | No of Units | Depth / PriceUnits | Unit Type | Land Type | LT Factor | Base Value | Unit Price | Adj | Neigh | Neigh Infl | Neigh Mod | Infl 1 | % | Infl 2 | % | Infl 3 | % | Appraised Value | Alt Class | % | Spec Land | J Code | Fact | Use Value | Notes |
|----------|-------------|----------|-------------|--------------------|-----------|------------|-----------|------------|------------|-------|-------|------------|-----------|--------|---|--------|---|--------|---|-----------------|-----------|---|-----------|--------|------|-----------|-------|
| 101 | ONE FAM | | 39639 | | SQUARE FE | PRIME SITE | | 0 | 8.08 | 1.713 | R4 | | | | | | | | | 548,565 | | | | | | 548,600 | |

IN PROCESS APPRAISAL SUMMARY

| Use Code | Building Value | Yard Items | Land Size | Land Value | Total Value | Legal Description | User Acct |
|---------------------------------------|----------------|------------|-----------|------------|-------------|-------------------|-----------|
| 101 | 259,000 | 1,300 | 0.910 | 548,600 | 808,900 | 2022 | 0 |
| Total Card | | | | | | Entered Lot Size | |
| Total Parcel | | | | | | Total Land: | |
| Source: Market Adj Cost | | | | | | Land Unit Type: | |
| Total Value per SQ unit /Card: 323.88 | | | | | | /Parcel: 323.88 | |

PREVIOUS ASSESSMENT

| Tax Yr | Use | Cat | Bldg Value | Yrd Items | Land Size | Land Value | Total Value | Asses'd Value | Notes | Date |
|--------|-----|-----|------------|-----------|-----------|------------|-------------|---------------|---------------|------------|
| 2018 | 101 | FV | 255,500 | 1300 | .91 | 548,600 | 805,400 | 805,400 | Year End Roll | 9/28/2017 |
| 2017 | 101 | FV | 241,100 | 1300 | .91 | 543,100 | 785,500 | 785,500 | Year End Roll | 9/29/2016 |
| 2016 | 101 | FV | 241,100 | 1300 | .91 | 527,500 | 769,900 | 769,900 | Year End Roll | 1/14/2016 |
| 2015 | 101 | FV | 231,600 | 1300 | .91 | 488,100 | 721,000 | 721,000 | Year End | 10/2/2014 |
| 2014 | 101 | FV | 229,300 | 1300 | .91 | 454,900 | 685,500 | 685,500 | Year End Roll | 1/23/2014 |
| 2013 | 101 | FV | 224,600 | 1300 | .91 | 441,300 | 667,200 | 667,200 | Year End Roll | 10/25/2012 |
| 2012 | 101 | FV | 224,600 | 1300 | .91 | 373,400 | 599,300 | 599,300 | Year End | 1/26/2012 |
| 2011 | 101 | FV | 229,300 | 1300 | .91 | 379,500 | 610,100 | 610,100 | Year End | 2/10/2011 |

SALES INFORMATION

| Grantor | Legal Ref | Type | Date | Sale Code | Sale Price | V | Tst | Verif | Assoc PCL Value | Notes |
|-----------------|-----------|------|------------|------------|------------|----|-----|-------|-----------------|-------|
| CAPPUCCI TR,THO | 58128-139 | | 12/20/2011 | FAMILY | | 0 | No | No | | |
| CAPPUCCI BARBAR | 56127-76 | | 12/22/2010 | | | 0 | No | No | | |
| CAPPUCCI BARBAR | 31275-450 | | 3/8/2000 | CONVENIENC | | 1 | No | No | | |
| CAPPUCCI, THOMA | 25288-95 | | 4/18/1995 | CONVENIENC | | 0 | No | No | | |
| HUNTLEY MEDFORD | 13355-588 | | 12/16/1977 | | 36000 | No | No | No | | |

BUILDING PERMITS

| Date | Number | Descp | Amount | C/O | Last Visit | Fed Code | F. Descp | Comment |
|-----------|--------|----------|--------|-----|------------|----------|----------|--------------------|
| 6/15/2017 | 6777 | RENOVATI | 22,440 | C | 7/18/2017 | | | Remodel a bathroom |
| 8/8/2016 | 6526 | KITCHEN | 36,000 | C | 2/7/2017 | | | Kitchen remodel |
| 9/15/2014 | 5901 | RENOVATI | 10,000 | C | 10/24/2014 | | | bathroom remodel |
| 9/5/2001 | 2335 | MANUAL | | C | 6/29/2002 | | | add support under |
| 10/3/2000 | 2100 | ROOF | | C | 6/8/2001 | | | |
| 9/21/2000 | 2089 | MANUAL | | C | 6/8/2001 | | | chimney |

ACTIVITY INFORMATION

| Date | Result | By | Name |
|------------|--------------|-----|------------|
| 5/27/2015 | PERMIT VISIT | 619 | DH |
| 11/11/2008 | MEAS/EXT INS | 25 | D ERSKINE |
| 6/29/2002 | MEAS/EXT INS | 613 | M COLE |
| 6/8/2001 | MEAS/EXT INS | 613 | M COLE |
| 4/18/1996 | MEAS+INSPCTD | 606 | J SMITH |
| 7/1/1989 | INSPECTED | 601 | PAUL MARSH |

Sign: VERIFICATION OF VISIT NOT DATA

EXTERIOR INFORMATION

| | | | |
|---------------|---------------|--------|------|
| Type: | 5 | - | CAPE |
| Sty Ht: | 1T | - | 1T |
| (Liv) Units: | 1 | Total: | 1 |
| Foundation: | 1 - CONCRETE | | |
| Frame: | 1 - WOOD | | |
| Prime Wall: | 2 - CLAPBOARD | | |
| Sec Wall: | | | |
| Roof Struct: | 1 - GABLE | | |
| Roof Cover: | 1 - ASPHALT | | |
| Color: | | | |
| View / Desir: | | | |

GENERAL INFORMATION

| | | | |
|---------------|---------------|-------------|--|
| Grade: | C+ - AVG. (+) | | |
| Year Blt: | 1979 | Eff Yr Blt: | |
| Alt LUC: | | Alt %: | |
| Jurisdic: | | Fact: | |
| Const Mod: | | | |
| Lump Sum Adj: | | | |

INTERIOR INFORMATION

| | | | |
|---------------|----------------|--------------|------------|
| Avg Ht/FL: | STD | | |
| Prim Int Wal: | 1 - DRYWALL | | |
| Sec Int Wall: | | | |
| Partition: | T - TYPICAL | | |
| Prim Floors: | 2 - SOFTWOOD | | |
| Sec Floors: | 4 | - | CARPET 50% |
| Bsmnt Flr: | | | |
| Bsmnt Gar: | | | |
| Electric: | 3 - TYPICAL | | |
| Insulation: | 2 - TYPICAL | | |
| Int vs Ext: | S | | |
| Heat Fuel: | 1 - OIL | | |
| Heat Type: | 3 - FORCED H/W | | |
| # Heat Sys: | 1 | | |
| % Heated: | 100 | % AC: | 100 |
| Solar HW: | NO | Central Vac: | NO |
| % Com Wal: | 0 | % Sprinkled: | 0 |

SPEC FEATURES/YARD ITEMS

| Code | Description | A | Y/S | Qty | Size/Dim | Qual | Con | Year | Unit Price | D/S | Dep | LUC | Fact | NB Fa | Appr Value | JCod | JFact | Juris. Value |
|------|-------------|---|-----|-----|----------|------|-----|------|------------|-----|-----|-----|------|-------|------------|------|-------|--------------|
| 2 | SHED/FR | D | Y | 1 | 80 | A | AV | 1979 | 15.00 | T | 70 | 101 | | | 400 | | | 400 |
| 2 | SHED/FR | D | Y | 1 | 200 | A | AV | 1979 | 15.00 | T | 70 | 101 | | | 900 | | | 900 |

| | | | | | | | |
|-------|---|-------------------|-------|-------------------------|--|--------|-------|
| More: | N | Total Yard Items: | 1,300 | Total Special Features: | | Total: | 1,300 |
|-------|---|-------------------|-------|-------------------------|--|--------|-------|

BATH FEATURES

| | | | |
|------------|---|---------|---------|
| Full Bath: | 1 | Rating: | GOOD |
| A Bath: | 1 | Rating: | AVERAGE |
| 3/4 Bath: | | Rating: | |
| A 3QBth: | | Rating: | |
| 1/2 Bath: | | Rating: | |
| A HBth: | | Rating: | |
| OthrFix: | 2 | Rating: | AVERAGE |

OTHER FEATURES

| | | | |
|---------|---|---------|---------|
| Kits: | 1 | Rating: | GOOD |
| A Kits: | | Rating: | |
| Frpl: | 1 | Rating: | AVERAGE |
| WSFlue: | 1 | Rating: | AVERAGE |

CONDO INFORMATION

| | | | |
|--------------|---------------|--|--|
| Location: | | | |
| Total Units: | | | |
| Floor: | 1 - 1ST FLOOR | | |
| % Own: | | | |
| Name: | | | |

DEPRECIATION

| | | |
|-------------|--------------|-----|
| Phys Cond: | AV - Average | 23% |
| Functional: | | % |
| Economic: | | % |
| Special: | | % |
| Override: | | % |
| Total: | | 23% |

CALC SUMMARY

| | |
|--------------------|------------|
| Basic \$ / SQ: | 79.00 |
| Size Adj.: | 0.99024022 |
| Const Adj.: | 1.00999999 |
| Adj \$ / SQ: | 79.011 |
| Other Features: | 59624 |
| Grade Factor: | 1.12 |
| Neighborhood Inf: | 1.00000000 |
| LUC Factor: | 1.00 |
| Adj Total: | 336312 |
| Depreciation: | 77352 |
| Depreciated Total: | 258961 |

COMMENTS

| | | | | | | | | | |
|--|--|--|--|--|--|--|--|--|--|
| | | | | | | | | | |
|--|--|--|--|--|--|--|--|--|--|

RESIDENTIAL GRID

| | | | | | | | | | | | | |
|--------------------|--------|----|--------|---|----------|----|---------|----|----|----|---|---|
| 1st Res Grid Desc: | Line 1 | | | | | | # Units | 1 | | | | |
| Level | FY | LR | DR | D | K | FR | RR | BR | FB | HB | L | O |
| Other | | | | | | | | | | | | |
| Upper | | | | | | | | | | | | |
| Lvl 2 | | | | | | | | | | | | |
| Lvl 1 | | | | | | | | | | | | |
| Lower | | | | | | | | | | | | |
| Totals | RMs: 8 | | BRs: 3 | | Baths: 1 | | HB | | | | | |

REMODELING

| | |
|------------|--|
| Exterior: | |
| Interior: | |
| Additions: | |
| Kitchen: | |
| Baths: | |
| Plumbing: | |
| Electric: | |
| Heating: | |
| General: | |

RES BREAKDOWN

| No Unit | RMS | BRS | FL |
|---------|-----|-----|----|
| 1 | 8 | 3 | |
| Totals | | | |
| 1 | 8 | 3 | |

COMPARABLE SALES

| Rate | Parcel ID | Typ | Date | Sale Price |
|------|-----------|-----|------|------------|
| | | | | |
| | | | | |
| | | | | |
| | | | | |
| | | | | |
| | | | | |
| | | | | |
| | | | | |
| | | | | |
| | | | | |
| | | | | |

| | | | | | |
|-------------------|--------|-------------|--------|---------|-------------|
| WtAv\$/SQ: | | AvRate: | | Ind.Val | 702789.5463 |
| Juris. Factor: | | Val/Su Fin: | 103.68 | | |
| Special Features: | 0 | Val/Su Net: | 58.33 | | |
| Final Total: | 259000 | Val/Su SzAd | 103.70 | | |

| | |
|-----------|----------|
| PARCEL ID | 174 20 0 |
|-----------|----------|

SKETCH

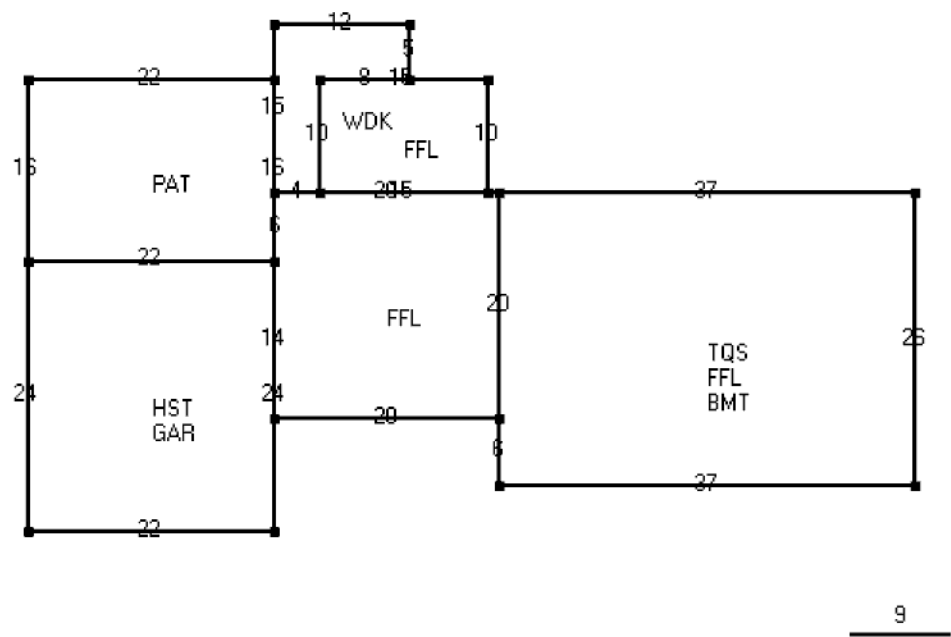

SUB AREA

| Code | Description | Area - SQ | Rate - AV | Undepr Value | |
|--------------------|-------------|------------|-----------|--------------|------|
| FFL | 1ST FLOOR | 1,512 | 79.010 | 119,465 | |
| BMT | BASEMENT | 962 | 19.750 | 19,002 | |
| TQS | 3/4 STORY | 722 | 79.010 | 57,007 | |
| GAR | GARAGE | 528 | 36.000 | 19,008 | |
| PAT | PATIO | 352 | 7.000 | 2,464 | |
| HST | HALF STORY | 264 | 79.010 | 20,859 | |
| WDK | WOOD DECK | 100 | 28.500 | 2,850 | |
| Net Sketched Area: | | 4,440 | Total: | 240,655 | |
| Size Ad | 2497.5 | Gross Area | 4944 | FinArea | 2498 |

SUB AREA DETAIL

| Sub Area | % Usbl | Descrip | % Type | Qu | # Ten |
|----------|--------|---------|--------|----|-------|
| | | | | | |
| | | | | | |
| | | | | | |
| | | | | | |
| | | | | | |
| | | | | | |
| | | | | | |
| | | | | | |
| | | | | | |
| | | | | | |
| | | | | | |

IMAGE

AssessPro Patriot Properties, Inc

