



Patriot
Properties Inc.

PROPERTY LOCATION

No	Alt No	Direction/Street/City
233		TOWER RD, LINCOLN

OWNERSHIP

Owner 1:	HATSOPOULOS GEORGE N		
Owner 2:	HATSOPOULOS DAPHNE		
Owner 3:			
Street 1:	233 TOWER RD		
Street 2:			
Twn/City:	LINCOLN		
St/Prov:	MA	Cntry:	Own Occ: Y
Postal:	01773-4329		Type:

PREVIOUS OWNER

Owner 1:			
Owner 2:			
Street 1:			
Twn/City:			
St/Prov:		Cntry:	
Postal:			

NARRATIVE DESCRIPTION

This Parcel contains 4.09 ACRES of land mainly classified as ONE FAM with a(n) CONTEMPORARY Building Built about 1974, Having Primarily STUCCO Exterior and MEMBRANE Roof Cover, with 1 Units, 4 Baths, 2 HalfBaths, 0 3/4 Baths, 9 Rooms, and 4 Bdrms.

OTHER ASSESSMENTS

Code	Descrip/No	Amount	Com. Int

PROPERTY FACTORS

Item	Code	Descp	%	Item	Code	Descp
Z	R1	Residential	100	U	A	SEPTIC
o				t		
n				l		
Census:				Exmpt		
Flood Haz:						
D				Topo		
s				Street	1	PAVED
t				Traffic	4	MEDIUM

LAND SECTION (First 7 lines only)

Use Code	Description	LUC Fact	No of Units	Depth / PriceUnits	Unit Type	Land Type	LT Factor	Base Value	Unit Price	Adj	Neigh	Neigh Influ	Neigh Mod	Infl 1	%	Infl 2	%	Infl 3	%	Appraised Value	Alt Class	%	Spec Land	J Code	Fact	Use Value	Notes
101	ONE FAM		80000		SQUARE FE	PRIME SITE		0	8.08	1.000	R4									646,400						646,400	
101	ONE FAM		1.773		ACRES	EXCESS ACRE		0	30,000.	1.000	R4									53,190						53,200	
101	ONE FAM		0.48		ACRES	UNDEV	0.2	0	30,000.	0.200	R4									2,880						2,900	Wetland

IN PROCESS APPRAISAL SUMMARY

Use Code	Building Value	Yard Items	Land Size	Land Value	Total Value	Legal Description	User Acct
101	1,568,100	9,000	4.090	702,500	2,279,600		
Total Card						Entered Lot Size	
Total Parcel						Total Land:	
Source: Market Adj Cost						Land Unit Type:	
Total Value per SQ unit /Card: 271.46						/Parcel: 271.46	

PREVIOUS ASSESSMENT

Tax Yr	Use	Cat	Bldg Value	Yrd Items	Land Size	Land Value	Total Value	Asses'd Value	Notes	Date
2018	101	FV	1,568,100	9000	4.09	702,500	2,279,600	2,279,600	Year End Roll	9/28/2017
2017	101	FV	1,371,800	9000	4.09	696,100	2,076,900	2,076,900	Year End Roll	9/29/2016
2016	101	FV	1,349,100	9000	4.09	677,700	2,035,800	2,035,800	Year End Roll	1/14/2016
2015	101	FV	1,311,800	9000	4.09	631,300	1,952,100	1,952,100	Year End	10/2/2014
2014	101	FV	1,212,300	9000	4.09	592,100	1,813,400	1,813,400	Year End Roll	1/23/2014
2013	101	FV	1,187,400	9000	4.09	576,100	1,772,500	1,772,500	Year End Roll	10/25/2012
2012	101	FV	1,187,400	9000	4.09	596,100	1,792,500	1,792,500	Year End	1/26/2012
2011	101	FV	1,258,000	9000	4.09	614,500	1,881,500	1,881,500	Year End	2/10/2011

SALES INFORMATION

Grantor	Legal Ref	Type	Date	Sale Code	Sale Price	V	Tst	Verif	Assoc PCL Value	Notes
LESLIE P. HEMRY	12355-585		12/29/1972		40000	No	No			

BUILDING PERMITS

Date	Number	Descp	Amount	C/O	Last Visit	Fed Code	F. Descp	Comment
9/9/1996	1041-96	MANUAL		C	5/23/1996			TP TENT

ACTIVITY INFORMATION

Date	Result	By	Name
5/8/2017	MEAS+INSPCTD	4	JG
7/16/2007	MEAS/EXT INS	617	D HASCHIG
5/23/1996	MEAS+INSPCTD	606	J SMITH

Sign: VERIFICATION OF VISIT NOT DATA

EXTERIOR INFORMATION

Table with exterior details: Type: 9 - CONTEMPORARY, Sty Ht: 1 - 1, (Liv) Units: 1, Total: 1, Foundation: 1 - CONCRETE, Frame: 1 - WOOD, Prime Wall: 6 - STUCCO, Sec Wall: %, Roof Struct: 7 - SHED, Roof Cover: 11 - MEMBRANE, Color: , View / Desir:

BATH FEATURES

Table with bath details: Full Bath: 4, Rating: GOOD, A Bath: , Rating: , 3/4 Bath: , Rating: , A 3QBth: , Rating: , 1/2 Bath: 2, Rating: GOOD, A HBth: , Rating: , OthrFix: 4, Rating: GOOD

COMMENTS

Empty table for comments.

GENERAL INFORMATION

Table with general info: Grade: A+ - EXCELLENT, Year Blt: 1974, Eff Yr Blt: , Alt LUC: , Alt %: , Jurisdict: , Fact: , Const Mod: , Lump Sum Adj:

OTHER FEATURES

Table with other features: Kits: 1, Rating: GOOD, A Kits: , Rating: , Frpl: 4, Rating: AVERAGE, WSFlue: , Rating:

CONDO INFORMATION

Table with condo info: Location: , Total Units: , Floor: 1 - 1ST FLOOR, % Own: , Name:

RESIDENTIAL GRID

Table with residential grid: 1st Res Grid, Desc: Line 1, # Units 1, Level FY LR DR D K FR RR BR FB HB L O, Other, Upper, Lvl 2, Lvl 1, Lower, Totals RMs: 9, BRs: 4, Baths: 4, HB 2

SKETCH

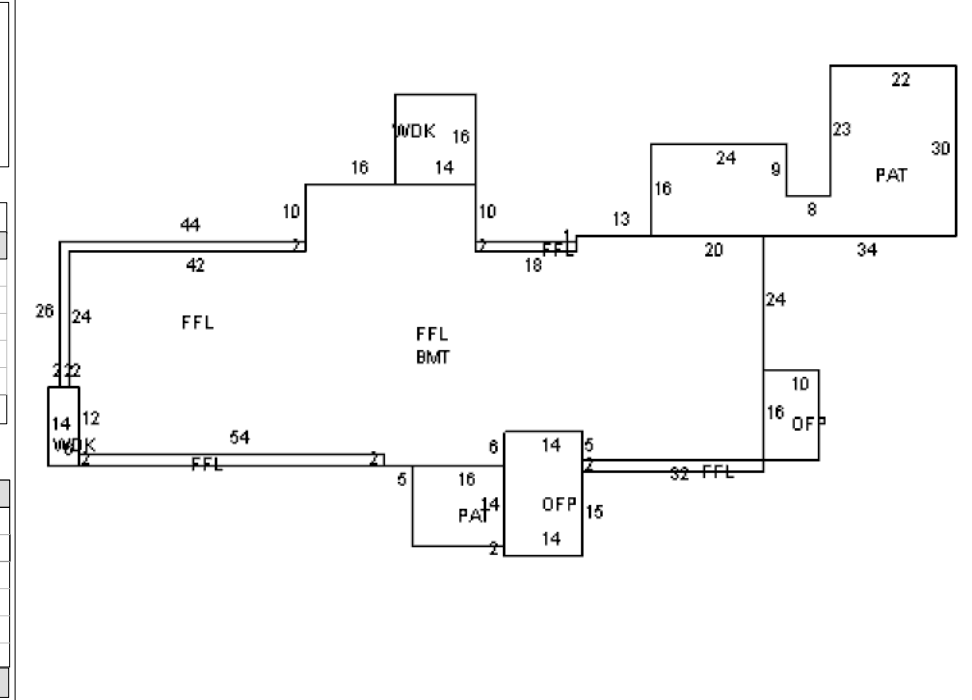

INTERIOR INFORMATION

Table with interior info: Avg Ht/FL: STD, Prim Int Wal: 1 - DRYWALL, Sec Int Wall: , Partition: T - TYPICAL, Prim Floors: 3 - HARDWOOD, Sec Floors: 6 - CERAMIC T, 50%, Bsmnt Flr:

DEPRECIATION

Table with depreciation: Phys Cond: AV - Average, 25.%, Functional: , Economic: , Special: , Override: , Total: 25%

REMODELING

Table with remodeling: Exterior: , Interior: , Additions: , Kitchen: , Baths: , Plumbing: , Electric: , Heating: , General:

RES BREAKDOWN

Table with res breakdown: No Unit, RMS, BRS, FL, Totals: 1, 9, 4, 1

INTERIOR INFORMATION

Table with interior info: Bsmnt Gar: 2, Electric: 3 - TYPICAL, Insulation: 2 - TYPICAL, Int vs Ext: S, Heat Fuel: 2 - GAS, Heat Type: 1 - FORCED H/A, # Heat Sys: 1, % Heated: 100, % AC: 100, Solar HW: NO, Central Vac: Yes, % Com Wal: 0, % Sprinkled: 0

CALC SUMMARY

Table with calc summary: Basic \$ / SQ: 91.00, Size Adj.: 0.86483252, Const Adj.: 0.99930596, Adj \$ / SQ: 78.645, Other Features: 124169, Grade Factor: 2.80, Neighborhood Inf: 1.00000000, LUC Factor: 1.00, Adj Total: 2090832, Depreciation: 522708, Depreciated Total: 1568124

COMPARABLE SALES

Table with comparable sales: Rate, Parcel ID, Typ, Date, Sale Price, WtAv\$/SQ, AvRate, Ind.Val 1920048.883, Juris. Factor, Val/Su Fin: 186.72, Special Features: 0, Val/Su Net: 128.47, Final Total: 1568100, Val/Su SzAdj: 300.11

SUB AREA

Table with sub area: Code, Description, Area - SQ, Rate - AV, Undepr Value, Net Sketched Area: 12,206, Total: 622,557, Size Ad: 5225, Gross Area: 12206, FinArea: 8398

SUB AREA DETAIL

Table with sub area detail: Sub Area, % Usbl, Descrip, % Type, Qu, # Ten

SPEC FEATURES/YARD ITEMS

Table with spec features/yard items: Code, Description, A, Y/S, Qty, Size/Dim, Qual, Con, Year, Unit Price, D/S, Dep, LUC, Fact, NB Fa, Appr Value, JCod, JFact, Juris. Value

PARCEL ID

190 15 0

IMAGE



AssessPro Patriot Properties, Inc

Summary table: More: N, Total Yard Items: 9,000, Total Special Features: , Total: 9,000