



**Patriot Properties Inc.**

**PROPERTY LOCATION**

No	Alt No	Direction/Street/City
17		ORCHARD LN, LINCOLN

**OWNERSHIP**

Owner 1:	HSU TR BO YEE LEUNG
Owner 2:	HSU TR NIEN HSI
Owner 3:	LEXINGTON HD1 TRUST
Street 1:	17 ORCHARD LN
Street 2:	
Twn/City:	LINCOLN
St/Prov:	MA Cntry Own Occ: Y
Postal:	01773 Type:

**PREVIOUS OWNER**

Owner 1:	GOTTLIEB PETER A -
Owner 2:	-
Street 1:	17 ORCHARD LN
Twn/City:	LINCOLN
St/Prov:	MA Cntry
Postal:	01773

**NARRATIVE DESCRIPTION**

This Parcel contains 1.97 ACRES of land mainly classified as ONE FAM with a(n) COLONIAL Building Built about 1997, Having Primarily CLAPBOARD Exterior and ASPHALT Roof Cover, with 1 Units, 2 Baths, 1 HalfBaths, 0 3/4 Baths, 9 Rooms, and 4 Bdrms.

**OTHER ASSESSMENTS**

Code	Descrip/No	Amount	Com. Int

**PROPERTY FACTORS**

Item	Code	Descp	%	Item	Code	Descp
Z	R1	Residential	100	U		
o				t		
n				l		
Census:				Exmpt		
Flood Haz:						
D				Topo		
s				Street	1	PAVED
t				Traffic	4	MEDIUM

**LAND SECTION (First 7 lines only)**

Use Code	Description	LUC Fact	No of Units	Depth / PriceUnits	Unit Type	Land Type	LT Factor	Base Value	Unit Price	Adj	Neigh	Neigh Infru	Neigh Mod	Infl 1	%	Infl 2	%	Infl 3	%	Appraised Value	Alt Class	%	Spec Land	J Code	Fact	Use Value	Notes
101	ONE FAM		80000		SQUARE FE	PRIME SITE		0	6.78	1.000	R3									542,400						542,400	
101	ONE FAM		0.1335		ACRES	EXCESS ACRE		0	30,000.	1.000	R3									4,005						4,000	

**IN PROCESS APPRAISAL SUMMARY**

Use Code	Building Value	Yard Items	Land Size	Land Value	Total Value	Legal Description	User Acct
101	692,000		1.970	546,400	1,238,400	z648	0
Total Card						Entered Lot Size	GIS Ref
Total Parcel						Total Land:	GIS Ref
Source: Market Adj Cost			Total Value per SQ unit /Card: 307.26		/Parcel: 307.26	Land Unit Type:	Insp Date
							08/13/08

**PREVIOUS ASSESSMENT**

Tax Yr	Use	Cat	Bldg Value	Yrd Items	Land Size	Land Value	Total Value	Asses'd Value	Notes	Date
2018	101	FV	696,700	0	1.97	546,400	1,243,100	1,243,100	Year End Roll	9/28/2017
2017	101	FV	648,900	0	1.97	516,000	1,164,900	1,164,900	Year End Roll	9/29/2016
2016	101	FV	630,300	0	1.97	500,800	1,131,100	1,131,100	Year End Roll	1/14/2016
2015	101	FV	624,700	0	1.97	464,000	1,088,700	1,088,700	Year End	10/2/2014
2014	101	FV	586,000	0	1.97	416,000	1,002,000	1,002,000	Year End Roll	1/23/2014
2013	101	FV	574,900	0	1.6	384,500	959,400	959,400	Year End Roll	10/25/2012
2012	101	FV	586,000	0	1.967	443,900	1,029,900	1,029,900	Year End	1/26/2012
2011	101	FV	597,000	0	1.967	451,100	1,048,100	1,048,100	Year End	2/10/2011

**SALES INFORMATION**

Grantor	Legal Ref	Type	Date	Sale Code	Sale Price	V	Tst	Verif	Assoc PCL Value	Notes
GOTTLIEB PETER	31343-534		4/26/2000		910900	No	No			
SNOW DEVELOPMEN	27596-114		8/21/1997		663609	No	No			
JULIANO, PAUL J	27164-187		3/27/1997	CHANGE IN US	225000	Yes	No			
FUNG MARGARET	18842-394		1/28/1988		223000	Yes	No			

**BUILDING PERMITS**

Date	Number	Descp	Amount	C/O	Last Visit	Fed Code	F. Descp	Comment
7/1/1997	1222	RENOVATI	8,500	C	4/4/1998			
2/19/1997	1133-97	NEW HOME	340,000	C	7/17/1997			55% 4/4/98 100%

**ACTIVITY INFORMATION**

Date	Result	By	Name
2/28/2018	INFO AT DOOR	622	K Cuoco
8/13/2008	MEAS/EXT INS	25	D ERSKINE
9/15/2001	ENTRY DENIED	613	M COLE
4/4/1998	MEAS/EXT INS	602	D TUCKER
7/17/1997	MEAS+INSPCTD	600	PA

Sign: VERIFICATION OF VISIT NOT DATA

Total AC/HA:	1.97005	Total SF/SM:	85815.38	Parcel LUC:	101 ONE FAM	Prime NB Desc	RES CAT 3	Total:	546,405	Spl Credit	Total:	546,400
--------------	---------	--------------	----------	-------------	-------------	---------------	-----------	--------	---------	------------	--------	---------

### EXTERIOR INFORMATION

Type:	6 - COLONIAL
Sty Ht:	2 - 2
(Liv) Units:	1 Total: 1
Foundation:	1 - CONCRETE
Frame:	1 - WOOD
Prime Wall:	2 - CLAPBOARD
Sec Wall:	%
Roof Struct:	2 - HIP
Roof Cover:	1 - ASPHALT
Color:	
View / Desir:	

### GENERAL INFORMATION

Grade:	A- - V GOOD-		
Year Blt:	1997	Eff Yr Blt:	
Alt LUC:		Alt %:	
Jurisdic:		Fact:	
Const Mod:			
Lump Sum Adj:			

### INTERIOR INFORMATION

Avg Ht/FL:	STD		
Prim Int Wal:	2 - PLASTER		
Sec Int Wall:	%		
Partition:	E - EXTNSIVE		
Prim Floors:	3 - HARDWOOD		
Sec Floors:	%		
Bsmnt Flr:			
Bsmnt Gar:			
Electric:	3 - TYPICAL		
Insulation:	2 - TYPICAL		
Int vs Ext:	S		
Heat Fuel:	1 - OIL		
Heat Type:	3 - FORCED H/W		
# Heat Sys:	1		
% Heated:	100	% AC:	100
Solar HW:	NO	Central Vac:	NO
% Com Wal:	0	% Sprinkled:	0

### SPEC FEATURES/YARD ITEMS

Code	Description	A	Y/S	Qty	Size/Dim	Qual	Con	Year	Unit Price	D/S	Dep	LUC	Fact	NB Fa	Appr Value	JCod	JFact	Juris. Value	
More: N	Total Yard Items:		Total Special Features:		Total:														

### BATH FEATURES

Full Bath:	2	Rating:	GOOD
A Bath:		Rating:	
3/4 Bath:		Rating:	
A 3QBth:		Rating:	
1/2 Bath:	1	Rating:	GOOD
A HBth:		Rating:	
OthrFix:	5	Rating:	AVERAGE

### OTHER FEATURES

Kits:	1	Rating:	GOOD
A Kits:		Rating:	
Frpl:	1	Rating:	AVERAGE
WSFlue:		Rating:	

### CONDO INFORMATION

Location:	
Total Units:	
Floor:	1 - 1ST FLOOR
% Own:	
Name:	

### CALC SUMMARY

Basic \$ / SQ:	88.00
Size Adj.:	0.93735361
Const Adj.:	1.01999998
Adj \$ / SQ:	84.137
Other Features:	75161
Grade Factor:	1.80
Neighborhood Inf:	1.00000000
LUC Factor:	1.00
Adj Total:	797244
Depreciation:	105236
Depreciated Total:	692008

### COMMENTS

### RESIDENTIAL GRID

1st Res Grid	Desc:	Line 1	# Units
Level	FY LR DR D K FR RR BR FB HB L O		
Other			
Upper			
Lvl 2			
Lvl 1			
Lower			
Totals	RMs: 9	BRs: 4	Baths: 2 HB 1

### REMODELING

Exterior:	
Interior:	
Additions:	
Kitchen:	
Baths:	
Plumbing:	
Electric:	
Heating:	
General:	

### RES BREAKDOWN

No Unit	RMS	BRS	FL
1	9	4	
Totals			
1	9	4	

### COMPARABLE SALES

Rate	Parcel ID	Typ	Date	Sale Price
WtAv\$/SQ:		AvRate:	Ind.Val	1075493.203
Juris. Factor:		Val/Su Fin:	171.67	
Special Features:	0	Val/Su Net:	112.59	
Final Total:	692000	Val/Su SzAd:	216.08	

### SKETCH

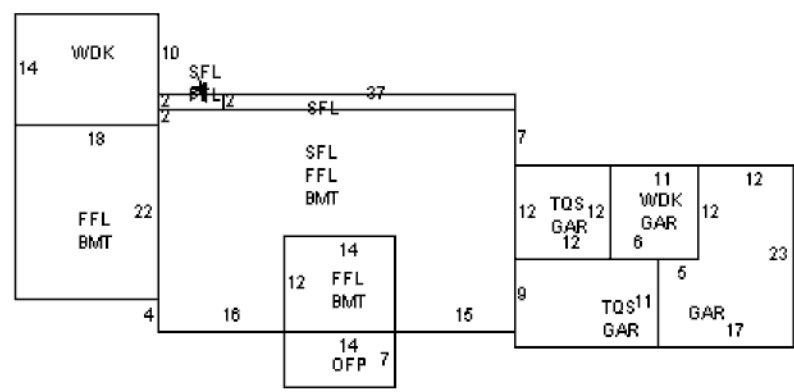

### SUB AREA

Code	Description	Area - SQ	Rate - AV	Undepr Value	
FFL	1ST FLOOR	1,672	84.140	140,677	
BMT	BASEMENT	1,656	36.810	60,957	
SFL	2ND FLOOR	1,274	84.140	107,190	
GAR	GARAGE	805	36.000	28,980	
WDK	WOOD DECK	384	17.960	6,897	
TQ\$	3/4 STORY	257	84.140	21,581	
OFF	OPEN PORCH	98	15.000	1,470	
Net Sketched Area:		6,146	Total:	367,752	
Size Ad	3202.5	Gross Area	6231	FinArea	4031

### SUB AREA DETAIL

Sub Area	% Usbl	Descrip	% Type	Qu	# Ten
BMT	100	FLA	50	A	

### IMAGE

AssessPro Patriot Properties, Inc



PARCEL ID 120 7 0