



Patriot Properties Inc.

PROPERTY LOCATION

No	Alt No	Direction/Street/City
42		BEDFORD RD, LINCOLN

OWNERSHIP

Owner 1:	GERTZ DWIGHT L
Owner 2:	WELLES VIRGINIA C
Owner 3:	
Street 1:	42 BEDFORD RD
Street 2:	
Twn/City:	LINCOLN
St/Prov:	MA Cntry Own Occ: Y
Postal:	01773-2037 Type:

PREVIOUS OWNER

Owner 1:	GERTZ - DWIGHT L
Owner 2:	WELLES - VIRGINIA C
Street 1:	42 BEDFORD RD
Twn/City:	LINCOLN
St/Prov:	MA Cntry
Postal:	01773-2037

NARRATIVE DESCRIPTION

This Parcel contains 3.27 ACRES of land mainly classified as ONE FAM with a(n) DECK HSE Building Built about 1978, Having Primarily WOOD Exterior and ASPHALT Roof Cover, with 1 Units, 4 Baths, 0 HalfBaths, 0 3/4 Baths, 10 Rooms, and 4 Bdrms.

OTHER ASSESSMENTS

Code	Descrip/No	Amount	Com. Int

PROPERTY FACTORS

Item	Code	Descp	%	Item	Code	Descp
Z	R1	Residential	100	U	A	SEPTIC
o				t		
n				l		
Census:				Exmpt		
Flood Haz:						
D				Topo		
s				Street	1	PAVED
t				Traffic	4	MEDIUM

LAND SECTION (First 7 lines only)

Use Code	Description	LUC Fact	No of Units	Depth / PriceUnits	Unit Type	Land Type	LT Factor	Base Value	Unit Price	Adj	Neigh	Neigh Infl	Neigh Mod	Infl 1	%	Infl 2	%	Infl 3	%	Appraised Value	Alt Class	%	Spec Land	J Code	Fact	Use Value	Notes
101	ONE FAM		80000		SQUARE FE	PRIME SITE		0	9.96	1.000	R5									796,800						796,800	
101	ONE FAM		1.163		ACRES	EXCESS ACRE		0	30,000.	1.000	R5									34,890						34,900	
101	ONE FAM		0.27		ACRES	UNDEV	0.2	0	30,000.	0.200	R5									1,620						1,600	Wetland

IN PROCESS APPRAISAL SUMMARY

Use Code	Building Value	Yard Items	Land Size	Land Value	Total Value	Legal Description	User Acct
101	382,100	500	3.270	833,300	1,215,900		
Total Card						Entered Lot Size	
Total Parcel						Total Land:	
Source: Market Adj Cost						Land Unit Type:	
Total Value per SQ unit /Card: 302.78						/Parcel: 302.78	

PREVIOUS ASSESSMENT

Tax Yr	Use	Cat	Bldg Value	Yrd Items	Land Size	Land Value	Total Value	Asses'd Value	Notes	Date
2018	101	FV	382,100	500	3.27	833,300	1,215,900	1,215,900	Year End Roll	9/28/2017
2017	101	FV	382,100	500	3.27	833,300	1,215,900	1,215,900	Year End Roll	9/29/2016
2016	101	FV	378,000	500	3.27	781,300	1,159,800	1,159,800	Year End Roll	1/14/2016
2015	101	FV	361,600	500	3.27	726,100	1,088,200	1,088,200	Year End	10/2/2014
2014	101	FV	357,500	500	3.27	716,500	1,074,500	1,074,500	Year End Roll	1/23/2014
2013	101	FV	349,300	500	3.27	696,500	1,046,300	1,046,300	Year End Roll	10/25/2012
2012	101	FV	376,600	500	3.27	716,500	1,093,600	1,093,600	Year End	1/26/2012
2011	101	FV	385,600	500	3.27	762,900	1,149,000	1,149,000	Year End	2/10/2011

SALES INFORMATION

Grantor	Legal Ref	Type	Date	Sale Code	Sale Price	V	Tst	Verif	Assoc PCL Value	Notes
GERTZ,DWIGHT L	65050-137		3/13/2015	CONVENIENC		1	No	No		
GRAY, LESLIE M	26434-256		6/25/1996		720000	No	No			
GORDON DORIS S	23664-329		9/17/1993		650000	No	No			

BUILDING PERMITS

Date	Number	Descp	Amount	C/O	Last Visit	Fed Code	F. Descp	Comment
12/18/2012	5277	SOLAR PA	36,000	C				install roof mount

ACTIVITY INFORMATION

Date	Result	By	Name
2/16/2017	MEAS/EXT INS	4	JG
7/16/2008	MEAS/EXT INS	25	D ERSKINE
3/2/2001	M&L COMPLETE	613	M COLE
5/1/1997	MEAS/EXT INS	600	PA
10/11/1995	MEAS/EXT INS	607	D KEARLY
6/1/1994	FIELDREV CHG	600	PA
11/1/1988	INSPECTED	601	PAUL MARSH

Sign: VERIFICATION OF VISIT NOT DATA

Total AC/HA:	3.26955	Total SF/SM:	142421.61	Parcel LUC:	101 ONE FAM	Prime NB Desc	RES CAT 5	Total:	833,310	SpI Credit		Total:	833,300
--------------	---------	--------------	-----------	-------------	-------------	---------------	-----------	--------	---------	------------	--	--------	---------

EXTERIOR INFORMATION

Type:	20	- DECK HSE
Sty Ht:	1	- 1
(Liv) Units:	1	Total: 1
Foundation:	1	- CONCRETE
Frame:	1	- WOOD
Prime Wall:	26	- WOOD
Sec Wall:		
Roof Struct:	1	- GABLE
Roof Cover:	1	- ASPHALT
Color:		
View / Desir:		

GENERAL INFORMATION

Grade:	C+	- AVG. (+)	
Year Blt:	1978	Eff Yr Blt:	
Alt LUC:		Alt %:	
Jurisdict:		Fact:	
Const Mod:			
Lump Sum Adj:			

INTERIOR INFORMATION

Avg Ht/FL:	STD		
Prim Int Wal:	1	- DRYWALL	
Sec Int Wall:			
Partition:	T	- TYPICAL	
Prim Floors:	3	- HARDWOOD	
Sec Floors:			
Bsmnt Flr:			
Bsmnt Gar:	2		
Electric:	3	- TYPICAL	
Insulation:	2	- TYPICAL	
Int vs Ext:	S		
Heat Fuel:	2	- GAS	
Heat Type:	3	- FORCED H/W	
# Heat Sys:	1		
% Heated:	100	% AC:	100
Solar HW:	NO	Central Vac:	NO
% Com Wal:	0	% Sprinkled:	0

BATH FEATURES

Full Bath:	4	Rating:	AVERAGE
A Bath:		Rating:	
3/4 Bath:		Rating:	
A 3QBth:		Rating:	
1/2 Bath:		Rating:	
A HBth:		Rating:	
OthrFix:	2	Rating:	AVERAGE

OTHER FEATURES

Kits:	1	Rating:	AVERAGE
A Kits:		Rating:	
Frpl:	2	Rating:	AVERAGE
WSFlue:		Rating:	

CONDO INFORMATION

Location:		
Total Units:		
Floor:	1	- 1ST FLOOR
% Own:		
Name:		

DEPRECIATION

Phys Cond:	AV	- Average	23.	%
Functional:				%
Economic:				%
Special:				%
Override:				%
Total:			23.4	%

CALC SUMMARY

Basic \$ / SQ:	78.00
Size Adj.:	0.99193549
Const Adj.:	1.01999998
Adj \$ / SQ:	78.918
Other Features:	65906
Grade Factor:	1.12
Neighborhood Inf:	1.00000000
LUC Factor:	1.00
Adj Total:	498813
Depreciation:	116722
Depreciated Total:	382091

COMMENTS

LONG SETBACK .

RESIDENTIAL GRID

1st Res Grid	Desc:	Line 1	# Units	1								
Level	FY	LR	DR	D	K	FR	RR	BR	FB	HB	L	O
Other												
Upper												
Lvl 2												
Lvl 1												
Lower												
Totals												

REMODELING

Exterior:	
Interior:	
Additions:	
Kitchen:	
Baths:	
Plumbing:	
Electric:	
Heating:	
General:	

RES BREAKDOWN

No Unit	RMS	BRS	FL
1	10	4	1
Totals			
1	10	4	

COMPARABLE SALES

Rate	Parcel ID	Typ	Date	Sale Price
WtAv\$/SQ:		AvRate:		Ind.Val 1027387.130
Juris. Factor:		Val/Su Fin:	95.14	
Special Features:	0	Val/Su Net:	76.21	
Final Total:	382100	Val/Su SzAd:	154.07	

SKETCH

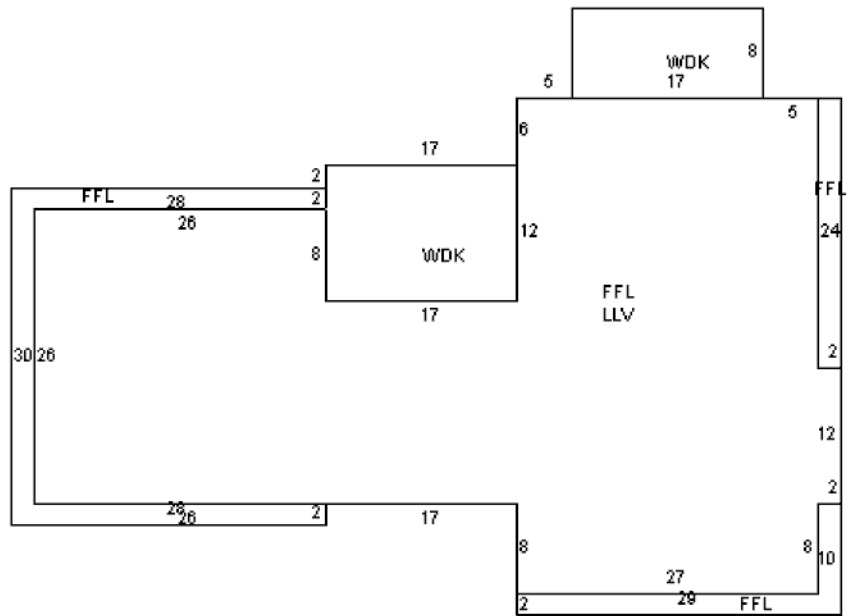

SUB AREA

Code	Description	Area - SQ	Rate - AV	Undepr Value	
FFL	1ST FLOOR	2,480	78.920	195,718	
LLV	LOWR LEVEL	2,194	80.890	177,476	
WDK	WOOD DECK	340	18.440	6,270	
Net Sketched Area:		5,014	Total:	379,464	
Size Ad	2480	Gross Area	5014	FinArea	4016

SUB AREA DETAIL

Sub Area	% Usbl	Descrip	% Type	Qu	# Ten
LLV	100	FLA	70	A	0

SPEC FEATURES/YARD ITEMS

Code	Description	A	Y/S	Qty	Size/Dim	Qual	Con	Year	Unit Price	D/S	Dep	LUC	Fact	NB Fa	Appr Value	JCod	JFact	Juris. Value
2	SHED/FR	D	Y	1	112	A	AV	1978	15.00	T	70	101			500			500

PARCEL ID

134 5 0

IMAGE

AssessPro Patriot Properties, Inc



More:	N	Total Yard Items:	500	Total Special Features:		Total:	500
-------	---	-------------------	-----	-------------------------	--	--------	-----