



**Patriot Properties Inc.**

**PROPERTY LOCATION**

No	Alt No	Direction/Street/City
127		LINCOLN RD, LINCOLN

**OWNERSHIP**

Owner 1:	SANDERSON IAN C
Owner 2:	SANDERSON ANNE LH
Owner 3:	
Street 1:	127 LINCOLN RD
Street 2:	
Twn/City:	LINCOLN
St/Prov:	MA Cntry Own Occ: Y
Postal:	01773-3812 Type:

**PREVIOUS OWNER**

Owner 1:	SANDERSON - IAN C
Owner 2:	SANDERSON - ANNE LH
Street 1:	127 LINCOLN RD
Twn/City:	LINCOLN
St/Prov:	MA Cntry
Postal:	01773-3812

**NARRATIVE DESCRIPTION**

This Parcel contains 8.567 ACRES of land mainly classified as ONE FAM with a(n) COLONIAL Building Built about 1993, Having Primarily CLAPBOARD Exterior and ASPHALT Roof Cover, with 1 Units, 4 Baths, 1 HalfBaths, 0 3/4 Baths, 13 Rooms, and 6 Bdrms.

**OTHER ASSESSMENTS**

Code	Descrip/No	Amount	Com. Int

**PROPERTY FACTORS**

Item	Code	Descp	%	Item	Code	Descp
Z	R1	Residential	100	U		
o				t		
n				l		
Census:				Exmpt		
Flood Haz:						
D				Topo		
s				Street	1	PAVED
t				Traffic	4	MEDIUM

**LAND SECTION (First 7 lines only)**

Use Code	Description	LUC Fact	No of Units	Depth / PriceUnits	Unit Type	Land Type	LT Factor	Base Value	Unit Price	Adj	Neigh	Neigh Influ	Neigh Mod	Infl 1	%	Infl 2	%	Infl 3	%	Appraised Value	Alt Class	%	Spec Land	J Code	Fact	Use Value	Notes
101	ONE FAM		80000		SQUARE FE	PRIME SITE		0	8.08	1.000	R4									646,400						646,400	
101	ONE FAM		6.73		ACRES	UNDEV	0.2	0	30,000.	0.200	R4									40,380						40,400	Wetland

**IN PROCESS APPRAISAL SUMMARY**

Use Code	Building Value	Yard Items	Land Size	Land Value	Total Value	Legal Description	User Acct
101	1,106,300	30,500	8.567	686,800	1,823,600		
Total Card						Entered Lot Size	
Total Parcel						Total Land:	
Source: Market Adj Cost						Land Unit Type:	
Total Value per SQ unit /Card: 326.15						/Parcel: 326.15	

**PREVIOUS ASSESSMENT**

Tax Yr	Use	Cat	Bldg Value	Yrd Items	Land Size	Land Value	Total Value	Asses'd Value	Notes	Date
2018	101	FV	1,106,300	30500	8.567	686,800	1,823,600	1,823,600	Year End Roll	9/28/2017
2017	101	FV	980,300	35600	8.567	680,400	1,696,300	1,696,300	Year End Roll	9/29/2016
2016	101	FV	938,400	35600	8.567	662,000	1,636,000	1,636,000	Year End Roll	1/14/2016
2015	101	FV	929,400	35600	8.567	615,600	1,580,600	1,580,600	Year End	10/2/2014
2014	101	FV	866,500	35600	8.567	576,400	1,478,500	1,478,500	Year End Roll	1/23/2014
2013	101	FV	848,500	35600	8.567	560,400	1,444,500	1,444,500	Year End Roll	10/25/2012
2012	101	FV	866,500	35600	8.57	719,700	1,621,800	1,621,800	Year End	1/26/2012
2011	101	FV	884,400	35600	8.57	766,000	1,686,000	1,686,000	Year End	2/10/2011

**SALES INFORMATION**

Grantor	Legal Ref	Type	Date	Sale Code	Sale Price	V	Tst	Verif	Assoc PCL Value	Notes
SANDERSON,IAN C	61523-257		4/2/2013	FAMILY		1	No	No		
GILFORD CONSTRU	22816-062		1/11/1993		539000	No	No			HOME FIN.BEFORE SALE

**BUILDING PERMITS**

Date	Number	Descp	Amount	C/O	Last Visit	Fed Code	F. Descp	Comment
7/3/2000	2017	MANUAL	100,000	C	5/19/2001			kitchen cabinets
2/19/1999	1628	ADDITION	60,000	C	6/5/1999			bedroom 5/31/00
6/27/1996	988-96	MANUAL	370,000	C	7/17/1997			GR + ADD
5/25/1993	247	FINISH B	5,000	C	7/8/1995			

**ACTIVITY INFORMATION**

Date	Result	By	Name
4/27/2017	MEAS/EXT INS	4	JG
6/26/2008	MEAS/EXT INS	25	D ERSKINE
5/19/2001	MEAS+INSPCTD	614	S FOLEY
5/31/2000	MEAS+INSPCTD	611	P MULHERN
6/5/1999	MEAS+INSPCTD	602	D TUCKER
3/30/1996	MEAS+INSPCTD	606	J SMITH
7/8/1995	MEAS/EXT INS	600	PA
4/27/1994	MEAS/EXT INS	600	PA
1/1/1994	M&L EXTERIOR	600	PA

Sign: VERIFICATION OF VISIT NOT DATA

Total AC/HA:	8.56655	Total SF/SM:	373158.94	Parcel LUC:	101 ONE FAM	Prime NB Desc	RES CAT 4	Total:	686,780	Spl Credit		Total:	686,800
--------------	---------	--------------	-----------	-------------	-------------	---------------	-----------	--------	---------	------------	--	--------	---------

**EXTERIOR INFORMATION**

Type:	6	- COLONIAL
Sty Ht:	2	- 2
(Liv) Units:	1	Total: 1
Foundation:	1	- CONCRETE
Frame:	1	- WOOD
Prime Wall:	2	- CLAPBOARD
Sec Wall:		%
Roof Struct:	1	- GABLE
Roof Cover:	1	- ASPHALT
Color:		
View / Desir:		

**GENERAL INFORMATION**

Grade:	A	- VERY GOOD
Year Blt:	1993	Eff Yr Blt:
Alt LUC:		Alt %:
Jurisdict:		Fact:
Const Mod:		
Lump Sum Adj:		

**INTERIOR INFORMATION**

Avg Ht/FL:	STD	
Prim Int Wal:	2	- PLASTER
Sec Int Wall:		%
Partition:	E	- EXTNSIVE
Prim Floors:	2	- SOFTWOOD
Sec Floors:		%
Bsmnt Flr:		
Bsmnt Gar:		
Electric:	3	- TYPICAL
Insulation:	2	- TYPICAL
Int vs Ext:	S	
Heat Fuel:	1	- OIL
Heat Type:	3	- FORCED H/W
# Heat Sys:	1	
% Heated:	100	% AC: 100
Solar HW:	NO	Central Vac: NO
% Com Wal:	0	% Sprinkled: 0

**BATH FEATURES**

Full Bath:	4	Rating:	AVERAGE
A Bath:		Rating:	
3/4 Bath:		Rating:	
A 3QBth:		Rating:	
1/2 Bath:	1	Rating:	AVERAGE
A HBth:		Rating:	
OthrFix:	4	Rating:	AVERAGE

**OTHER FEATURES**

Kits:	1	Rating:	VERY GOOD
A Kits:		Rating:	
Frpl:	2	Rating:	AVERAGE
WSFlue:		Rating:	

**CONDO INFORMATION**

Location:		
Total Units:		
Floor:	1	- 1ST FLOOR
% Own:		
Name:		

**DEPRECIATION**

Phys Cond:	VG	- Very Good	5.4	%
Functional:				%
Economic:				%
Special:				%
Override:				%
Total:			5.4	%

**CALC SUMMARY**

Basic \$ / SQ:	88.00
Size Adj.:	0.89492750
Const Adj.:	1.01999998
Adj \$ / SQ:	80.329
Other Features:	93957
Grade Factor:	2.25
Neighborhood Inf:	1.00000000
LUC Factor:	1.00
Adj Total:	1169428
Depreciation:	63149
Depreciated Total:	1106279

**COMMENTS**

INCL R/W 84-1-2 (.42 AC). Finished, heated room above garage. .

**RESIDENTIAL GRID**

1st Res Grid	Desc:	Line 1	# Units	1		
Level	FY LR DR D K FR RR BR FB HB L O					
Other						
Upper						
Lvl 2						
Lvl 1						
Lower						
Totals			RMs: 13	BRs: 6	Baths: 4	HB: 1

**REMODELING**

Exterior:	
Interior:	
Additions:	1999
Kitchen:	
Baths:	
Plumbing:	
Electric:	
Heating:	
General:	

**RES BREAKDOWN**

No Unit	RMS	BRS	FL
1	13	6	
Totals			
1	13	6	

**COMPARABLE SALES**

Rate	Parcel ID	Typ	Date	Sale Price
WtAv\$/SQ:		AvRate:		Ind.Val 1538780.339
Juris. Factor:		Val/Su Fin:	197.87	
Special Features:	0	Val/Su Net:	171.81	
Final Total:	1106300	Val/Su SzAd:	267.22	

**SKETCH**

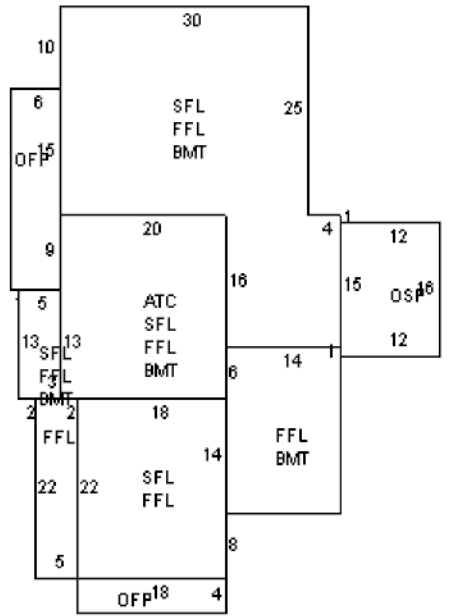

**SUB AREA**

Code	Description	Area - SQ	Rate - AV	Undepr Value	
FFL	1ST FLOOR	2,265	80.330	181,944	
SFL	2ND FLOOR	1,875	80.330	150,616	
BMT	BASEMENT	1,759	42.670	75,065	
OPF	OPEN PORCH	216	15.000	3,240	
OSP	SCRN PORCH	192	22.500	4,320	
ATC	ATTIC	132	80.330	10,603	
Net Sketched Area:		6,439	Total:	425,788	
Size Ad	4140	Gross Area	6747	FinArea	5591

**SUB AREA DETAIL**

Sub Area	% Usbl	Descrip	% Type	Qu	# Ten
BMT	100	FLA	75	A	0

**SPEC FEATURES/YARD ITEMS**

Code	Description	A	Y/S	Qty	Size/Dim	Qual	Con	Year	Unit Price	D/S	Dep	LUC	Fact	NB Fa	Appr Value	JCod	JFact	Juris. Value
4	GARAGE/L	D	Y	1	24X32	V	AV	1997	42.00	B	5.4	101			30,500			30,500

**PARCEL ID** 162 44 0

More: N

Total Yard Items: 30,500 Total Special Features:

Total: 30,500

**IMAGE**

*AssessPro* Patriot Properties, Inc

