



**Patriot Properties Inc.**

**PROPERTY LOCATION**

No	Alt No	Direction/Street/City
97		LINCOLN RD, LINCOLN

**OWNERSHIP**

Owner 1:	CLARK TIMOTHY J
Owner 2:	JOHNSEN KATE
Owner 3:	
Street 1:	97 LINCOLN RD
Street 2:	
Twn/City:	LINCOLN
St/Prov:	MA Cntry Own Occ: Y
Postal:	01773-3805 Type:

**PREVIOUS OWNER**

Owner 1:	JONES - SUSAN C
Owner 2:	-
Street 1:	97 LINCOLN RD
Twn/City:	LINCOLN
St/Prov:	MA Cntry
Postal:	01773-3805

**NARRATIVE DESCRIPTION**

This Parcel contains 1.55 ACRES of land mainly classified as ONE FAM with a(n) CONTEMPORARY Building Built about 1986, Having Primarily WOOD SHING Exterior and ASPHALT Roof Cover, with 1 Units, 3 Baths, 1 HalfBaths, 0 3/4 Baths, 8 Rooms, and 3 Bdrms.

**OTHER ASSESSMENTS**

Code	Descrip/No	Amount	Com. Int

**PROPERTY FACTORS**

Item	Code	Descp	%	Item	Code	Descp
Z	R1	Residential	100	U	A	SEPTIC
o				t		
n				l		
Census:				Exmpt		
Flood Haz:						
D				Topo		
s				Street	1	PAVED
t				Traffic	4	MEDIUM

**LAND SECTION (First 7 lines only)**

Use Code	Description	LUC Fact	No of Units	Depth / PriceUnits	Unit Type	Land Type	LT Factor	Base Value	Unit Price	Adj	Neigh	Neigh Infru	Neigh Mod	Infl 1	%	Infl 2	%	Infl 3	%	Appraised Value	Alt Class	%	Spec Land	J Code	Fact	Use Value	Notes
101	ONE FAM		67518		SQUARE FE	PRIME SITE		0	6.78	1.129	R3									517,012						517,000	

**IN PROCESS APPRAISAL SUMMARY**

Use Code	Building Value	Yard Items	Land Size	Land Value	Total Value	Legal Description	User Acct			
101	1,032,600		1.550	517,000	1,549,600	1510	0			
							GIS Ref			
							GIS Ref			
Total Card					1,032,600	1.550	517,000	1,549,600	Entered Lot Size	
Total Parcel					1,032,600	1.550	517,000	1,549,600	Total Land:	
Source: Market Adj Cost			Total Value per SQ unit /Card:		395.71	/Parcel:	395.71	Land Unit Type:		

**PREVIOUS ASSESSMENT**

Tax Yr	Use	Cat	Bldg Value	Yrd Items	Land Size	Land Value	Total Value	Asses'd Value	Notes	Date
2018	101	FV	1,032,600	0	1.55	517,000	1,549,600	1,549,600	Year End Roll	9/28/2017
2017	101	FV	925,600	0	1.55	488,000	1,413,600	1,413,600	Year End Roll	9/29/2016
2016	101	FV	891,000	0	1.55	473,500	1,364,500	1,364,500	Year End Roll	1/14/2016
2015	101	FV	868,800	0	1.55	438,500	1,307,300	1,307,300	Year End	10/2/2014
2014	101	FV	770,800	0	1.55	392,700	1,163,500	1,163,500	Year End Roll	1/23/2014
2013	101	FV	755,900	0	1.55	381,300	1,137,200	1,137,200	Year End Roll	10/25/2012
2012	101	FV	755,900	0	1.55	399,600	1,155,500	1,155,500	Year End	1/26/2012
2011	101	FV	770,800	0	1.55	406,200	1,177,000	1,177,000	Year End	2/10/2011

**SALES INFORMATION**

Grantor	Legal Ref	Type	Date	Sale Code	Sale Price	V	Tst	Verif	Assoc PCL Value	Notes
JONES,SUSAN C	71197-361		6/22/2018		1400000	No	No			
PERRY JUDITH S,	31304-326		4/3/2000		975000	No	No			
FUNARO, KATHERI	25413-320		6/16/1995		662500	No	No			
ENRICO FUNARO	20914-368		12/14/1990	FAMILY	0	No	No			

**BUILDING PERMITS**

Date	Number	Descp	Amount	C/O	Last Visit	Fed Code	F. Descp	Comment
7/20/2015	6169	RENOVATI	30,000	C	3/10/2016			Remodel 2nd floor
1/23/2014	5633	RENOVATI	15,000	C	5/13/2014			bath remodel
3/29/2013	5351	KITCHEN	80,000	C	5/13/2014			remodel existing k
6/25/2001	2280	ROOF		C				
11/16/1998	1584	MANUAL	10,000	C	4/14/1999			enlarge bathroom
8/18/1997	1254	ROOF		C	3/3/1998			3/3/98 100%
7/25/1995	778-95	FENCE	1,850	C	3/29/1996			
6/27/1995	756-95	FINISH B		C	3/29/1996			
6/12/1995	744-95	RENO-ADD	8,000	C	3/29/1996			

**ACTIVITY INFORMATION**

Date	Result	By	Name
5/13/2014	MEAS/EXT INS	25	D ERSKINE
7/26/2007	MEAS+INSPCTD	617	D HASCHIG
4/14/1999	MEAS+INSPCTD	602	D TUCKER
3/3/1998	MEAS/EXT INS	602	D TUCKER
3/29/1996	MEAS+INSPCTD	606	J SMITH

Sign: VERIFICATION OF VISIT NOT DATA

**EXTERIOR INFORMATION**

Type:	9 - CONTEMPORARY
Sty Ht:	2 - 2
(Liv) Units:	1 Total: 1
Foundation:	1 - CONCRETE
Frame:	1 - WOOD
Prime Wall:	1 - WOOD SHING
Sec Wall:	%
Roof Struct:	1 - GABLE
Roof Cover:	1 - ASPHALT
Color:	
View / Desir:	

**GENERAL INFORMATION**

Grade:	A - VERY GOOD
Year Blt:	1986 Eff Yr Blt:
Alt LUC:	Alt %:
Jurisdict:	Fact:
Const Mod:	
Lump Sum Adj:	

**INTERIOR INFORMATION**

Avg Ht/FL:	STD	
Prim Int Wal:	1 - DRYWALL	
Sec Int Wall:	%	
Partition:	E - EXTNSIVE	
Prim Floors:	3 - HARDWOOD	
Sec Floors:	%	
Bsmnt Flr:		
Bsmnt Gar:		
Electric:	1 - EXTENSIVE	
Insulation:	3 - EXTENSIVE	
Int vs Ext:	S	
Heat Fuel:	1 - OIL	
Heat Type:	1 - FORCED H/A	
# Heat Sys:	1	
% Heated:	100 % AC:	100
Solar HW:	Yes Central Vac:	Yes
% Com Wal:	0 % Sprinkled:	0

Basic \$ / SQ:	91.00
Size Adj.:	0.92641872
Const Adj.:	1.01999998
Adj \$ / SQ:	85.990
Other Features:	91704
Grade Factor:	2.25
Neighborhood Inf:	1.00000000
LUC Factor:	1.00
Adj Total:	1117538
Depreciation:	84933
Depreciated Total:	1032605

**SPEC FEATURES/YARD ITEMS**

Code	Description	A	Y/S	Qty	Size/Dim	Qual	Con	Year	Unit Price	D/S	Dep	LUC	Fact	NB Fa	Appr Value	JCod	JFact	Juris. Value

**BATH FEATURES**

Full Bath:	3 Rating:	GOOD
A Bath:		
3/4 Bath:		
A 3QBth:		
1/2 Bath:	1 Rating:	GOOD
A HBth:		
OthrFix:	3 Rating:	AVERAGE

**OTHER FEATURES**

Kits:	1 Rating:	GOOD
A Kits:		
Frpl:	3 Rating:	AVERAGE
WSFlue:		

**CONDO INFORMATION**

Location:	
Total Units:	
Floor:	1 - 1ST FLOOR
% Own:	
Name:	

**COMMENTS**

**RESIDENTIAL GRID**

1st Res Grid	Desc:	Line 1	# Units	1	
Level	FY LR DR D K FR RR BR FB HB L O				
Other					
Upper					
Lvl 2					
Lvl 1					
Lower					
Totals	RM:	8 BR:	3 Baths:	3 HB:	1

**REMODELING**

Exterior:	
Interior:	
Additions:	
Kitchen:	
Baths:	
Plumbing:	
Electric:	
Heating:	
General:	

**RES BREAKDOWN**

No Unit	RMS	BRS	FL
1	8	3	
<b>Totals</b>			
1	8	3	

**CALC SUMMARY**

**COMPARABLE SALES**

Rate	Parcel ID	Typ	Date	Sale Price

WtAv\$/SQ:	AvRate:	Ind.Val	1251506.310
Juris. Factor:		Val/Su Fin:	263.69
Special Features:	0	Val/Su Net:	130.66
Final Total:	1032600	Val/Su SzAd:	303.62

**SKETCH**

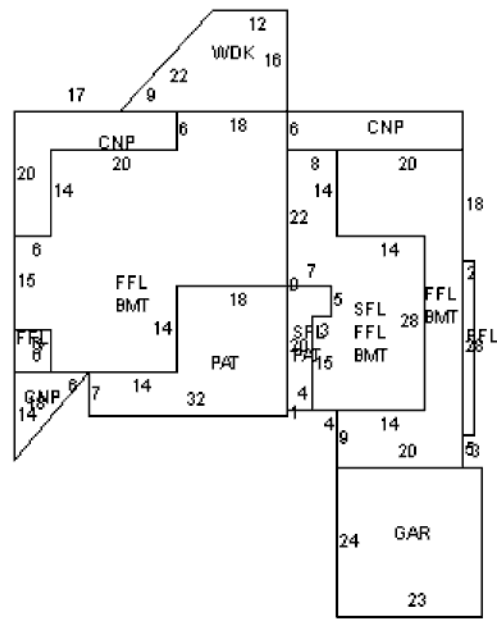

**SUB AREA**

**SUB AREA DETAIL**

Code	Description	Area - SQ	Rate - AV	Undepr Value	
FFL	1ST FLOOR	2,673	85.990	229,852	
BMT	BASEMENT	2,575	27.950	71,963	
SFL	2ND FLOOR	728	85.990	62,601	
PAT	PATIO	571	7.000	3,997	
GAR	GARAGE	552	36.000	19,872	
CNP	CANOPY	492	22.000	10,824	
WDK	WOOD DECK	312	18.820	5,871	
Net Sketched Area:		7,903	Total:	404,980	
Size Ad	3401	Gross Area	7903	FinArea	3916

**IMAGE**

**AssessPro** Patriot Properties, Inc



**PARCEL ID** 162 50 0