



Patriot Properties Inc.

PROPERTY LOCATION

No	Alt No	Direction/Street/City
101		LINCOLN RD, LINCOLN

OWNERSHIP

Owner 1:	GALLO ROGER E
Owner 2:	
Owner 3:	
Street 1:	101 LINCOLN RD
Street 2:	
Twn/City:	LINCOLN
St/Prov:	MA Cntry Own Occ: Y
Postal:	01773-3805 Type:

PREVIOUS OWNER

Owner 1:	OROURKE PAUL C -
Owner 2:	OROURKE MARILYN -
Street 1:	101 LINCOLN RD
Twn/City:	LINCOLN
St/Prov:	MA Cntry
Postal:	01773-3805

NARRATIVE DESCRIPTION

This Parcel contains 1.847 ACRES of land mainly classified as ONE FAM with a(n) CONTEMPORARY Building Built about 1986, Having Primarily WOOD SHING Exterior and ASPHALT Roof Cover, with 1 Units, 3 Baths, 1 HalfBaths, 0 3/4 Baths, 12 Rooms, and 4 Bdrms.

OTHER ASSESSMENTS

Code	Descrip/No	Amount	Com. Int

PROPERTY FACTORS

Item	Code	Descp	%	Item	Code	Descp
Z	R1	Residential	100	U	A	SEPTIC
o				t		
n				l		
Census:				Exmpt		
Flood Haz:						
D				Topo		
s				Street	1	PAVED
t				Traffic	4	MEDIUM

LAND SECTION (First 7 lines only)

Use Code	Description	LUC Fact	No of Units	Depth / PriceUnits	Unit Type	Land Type	LT Factor	Base Value	Unit Price	Adj	Neigh	Neigh Infl	Neigh Mod	Infl 1	%	Infl 2	%	Infl 3	%	Appraised Value	Alt Class	%	Spec Land	J Code	Fact	Use Value	Notes
101	ONE FAM		80000		SQUARE FE	PRIME SITE		0	8.08	1.000	R4									646,400						646,400	
101	ONE FAM		0.01		ACRES	UNDEV	0.2	0	30,000.	0.200	R4									60						100	Wetland

IN PROCESS APPRAISAL SUMMARY

Use Code	Building Value	Yard Items	Land Size	Land Value	Total Value	Legal Description	User Acct
101	1,265,000		1.847	646,500	1,911,500		0
							GIS Ref
							GIS Ref
Total Card	1,265,000		1.847	646,500	1,911,500	Entered Lot Size	
Total Parcel	1,265,000		1.847	646,500	1,911,500	Total Land:	
Source:	Market Adj Cost	Total Value per SQ unit /Card:		369.02	/Parcel:	369.02	Insp Date
						Land Unit Type:	05/22/08

PREVIOUS ASSESSMENT

Tax Yr	Use	Cat	Bldg Value	Yrd Items	Land Size	Land Value	Total Value	Asses'd Value	Notes	Date
2018	101	FV	1,265,000	0	1.847	646,500	1,911,500	1,911,500	Year End Roll	9/28/2017
2017	101	FV	1,132,000	0	1.847	640,100	1,772,100	1,772,100	Year End Roll	9/29/2016
2016	101	FV	1,094,300	0	1.847	621,700	1,716,000	1,716,000	Year End Roll	1/14/2016
2015	101	FV	1,064,100	0	1.847	575,300	1,639,400	1,639,400	Year End	10/2/2014
2014	101	FV	983,700	0	1.847	536,100	1,519,800	1,519,800	Year End Roll	1/23/2014
2013	101	FV	963,600	0	1.847	520,100	1,483,700	1,483,700	Year End Roll	10/25/2012
2012	101	FV	963,600	0	1.85	471,300	1,434,900	1,434,900	Year End	1/26/2012
2011	101	FV	983,700	0	1.85	487,200	1,470,900	1,470,900	Year End	2/10/2011

SALES INFORMATION

Grantor	Legal Ref	Type	Date	Sale Code	Sale Price	V	Tst	Verif	Assoc PCL Value	Notes
OROURKE PAUL C,	43374-458		7/27/2004		1771500	No	No			
COUNTRYSIDE CON	16656-169		12/20/1985		725000	No	No			

BUILDING PERMITS

Date	Number	Descp	Amount	C/O	Last Visit	Fed Code	F. Descp	Comment
2/26/2018	6983	MANUAL	1,737	O				Weatherization & a
3/1/2017	6677	SHEET MT	1,500	O				Sheet metal work f
1/4/2017	6657	KITCHEN	140,000	O				Remodel the kitch
11/23/2015	6294	RENOVATI	38,000	O				Remove existing de
11/28/2012	5253	SOLAR PA	45,325	C				install roof mount
3/26/2008	3898	RENOVATI	35,660	C	5/22/2008			remodel 3 season p
8/30/2004	3021	RENOVATI	10,000	C	5/28/2005			reno base to plyrm
8/19/1998	1496	ROOF	14,000	C	3/20/1999			

ACTIVITY INFORMATION

Date	Result	By	Name
6/7/2016	PERMIT VISIT	618	G BOURGAULT
5/26/2009	PERMIT VISIT	25	D ERSKINE
5/22/2008	MEAS/EXT INS	100	B MORGAN
5/28/2005	MEAS/EXT INS	615	D VELUTTI
4/19/2005	MEAS/EXT INS	600	PA
3/20/1999	MEAS/EXT INS	602	D TUCKER
3/29/1996	MEAS/EXT INS	606	J SMITH

Sign: VERIFICATION OF VISIT NOT DATA

Total AC/HA: 1.84655 Total SF/SM: 80435.72 Parcel LUC: 101 ONE FAM Prime NB Desc RES CAT 4 Total: 646,460 Spl Credit Total: 646,500

EXTERIOR INFORMATION

Type:	9	- CONTEMPORARY
Sty Ht:	2	- 2
(Liv) Units:	1	Total: 1
Foundation:	1	- CONCRETE
Frame:	1	- WOOD
Prime Wall:	1	- WOOD SHING
Sec Wall:		
Roof Struct:	1	- GABLE
Roof Cover:	1	- ASPHALT
Color:		
View / Desir:		

BATH FEATURES

Full Bath:	3	Rating:	AVERAGE
A Bath:		Rating:	
3/4 Bath:		Rating:	
A 3QBth:		Rating:	
1/2 Bath:	1	Rating:	AVERAGE
A HBth:		Rating:	
OthrFix:	4	Rating:	AVERAGE

COMMENTS

FFL,BMT,WDK,OPF ANGLED .

RESIDENTIAL GRID

1st Res Grid	Desc:	Line 1	# Units	1								
Level	FY	LR	DR	D	K	FR	RR	BR	FB	HB	L	O
Other												
Upper												
Lvl 2												
Lvl 1												
Lower												
Totals												
RMs:	12	BRs:	4	Baths:	3	HB	1					

OTHER FEATURES

Kits:	1	Rating:	GOOD
A Kits:		Rating:	
Frpl:	3	Rating:	AVERAGE
WSFlue:		Rating:	

GENERAL INFORMATION

Grade:	A	- VERY GOOD	
Year Blt:	1986	Eff Yr Blt:	
Alt LUC:		Alt %:	
Jurisdct:		Fact:	
Const Mod:			
Lump Sum Adj:			

CONDO INFORMATION

Location:		
Total Units:		
Floor:	1	- 1ST FLOOR
% Own:		
Name:		

REMODELING

Exterior:	
Interior:	
Additions:	
Kitchen:	
Baths:	
Plumbing:	
Electric:	
Heating:	
General:	

RES BREAKDOWN

No Unit	RMS	BRS	FL
1	12	4	
Totals			
1	12	4	

INTERIOR INFORMATION

Avg Ht/FL:	STD		
Prim Int Wal:	2	- PLASTER	
Sec Int Wall:			
Partition:	E	- EXTNSIVE	
Prim Floors:	3	- HARDWOOD	
Sec Floors:			
Bsmnt Flr:			
Bsmnt Gar:			
Electric:	3	- TYPICAL	
Insulation:	2	- TYPICAL	
Int vs Ext:	S		
Heat Fuel:	2	- GAS	
Heat Type:	14	- HVAC	
# Heat Sys:	1		
% Heated:	100	% AC:	100
Solar HW:	NO	Central Vac:	NO
% Com Wal:	0	% Sprinkled:	0

DEPRECIATION

Phys Cond:	VG	- Very Good	7.6%
Functional:			
Economic:			
Special:			
Override:			
Total:			7.6%

CALC SUMMARY

Basic \$ / SQ:	91.00
Size Adj.:	0.86583012
Const Adj.:	1.05059993
Adj \$ / SQ:	82.777
Other Features:	77563
Grade Factor:	2.25
Neighborhood Inf:	1.00000000
LUC Factor:	1.00
Adj Total:	1369056
Depreciation:	104048
Depreciated Total:	1265008

COMPARABLE SALES

Rate	Parcel ID	Typ	Date	Sale Price	
WtAv\$/SQ:		AvRate:		Ind.Val	1350498.648
Juris. Factor:		Val/Su Fin:	244.21		
Special Features:	0	Val/Su Net:	127.76		
Final Total:	1265000	Val/Su SzAd:	244.21		

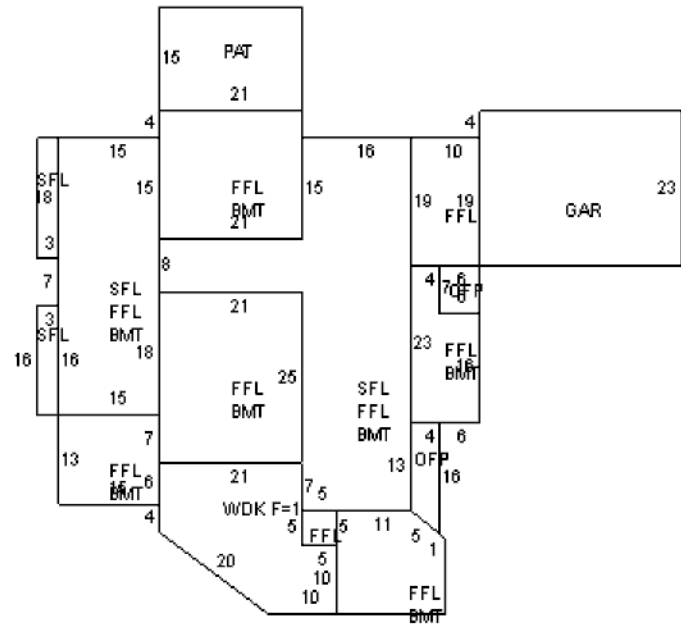
SKETCH**SUB AREA**

Code	Description	Area - SQ	Rate - AV	Undepr Value	
FFL	1ST FLOOR	3,415	82.780	282,685	
BMT	BASEMENT	3,200	20.690	66,222	
SFL	2ND FLOOR	1,765	82.780	146,102	
GAR	GARAGE	690	36.000	24,840	
WDK	WOOD DECK	416	17.680	7,353	
PAT	PATIO	315	7.000	2,205	
OPF	OPEN PORCH	100	15.000	1,500	
Net Sketched Area:		9,901	Total:	530,907	
Size Ad	5180	Gross Area	9901	FinArea	5180

SUB AREA DETAIL

Sub Area	% Usbl	Descrip	% Type	Qu	# Ten

SPEC FEATURES/YARD ITEMS

Code	Description	A	Y/S	Qty	Size/Dim	Qual	Con	Year	Unit Price	D/S	Dep	LUC	Fact	NB Fa	Appr Value	JCod	JFact	Juris. Value

More: N Total Yard Items: Total Special Features: Total:

IMAGE

AssessPro Patriot Properties, Inc

