



Patriot Properties Inc.

PROPERTY LOCATION

| No | Alt No | Direction/Street/City |
|----|--------|-----------------------|
| 10 | | CERULEAN WY, LINCOLN |

OWNERSHIP

| | |
|-----------|---------------------|
| Owner 1: | NATHANIEL ROBERT |
| Owner 2: | |
| Owner 3: | |
| Street 1: | 10 CERULEAN WY |
| Street 2: | |
| Twn/City: | LINCOLN |
| St/Prov: | MA Cntry Own Occ: Y |
| Postal: | 01773-4300 Type: |

PREVIOUS OWNER

| | |
|-----------|-------|
| Owner 1: | |
| Owner 2: | |
| Street 1: | |
| Twn/City: | |
| St/Prov: | Cntry |
| Postal: | |

NARRATIVE DESCRIPTION

This Parcel contains 1.85 ACRES of land mainly classified as ONE FAM with a(n) CONTEMPORARY Building Built about 1990, Having Primarily WOOD SHING Exterior and WOODSHINGL Roof Cover, with 1 Units, 4 Baths, 4 HalfBaths, 0 3/4 Baths, 10 Rooms, and 4 Bdrms.

OTHER ASSESSMENTS

| Code | Descrip/No | Amount | Com. Int |
|------|------------|--------|----------|
| | | | |

PROPERTY FACTORS

| Item | Code | Descp | % | Item | Code | Descp |
|------------|------|-------------|-----|---------|------|--------|
| Z | R1 | Residential | 100 | U | A | SEPTIC |
| o | | | | t | | |
| n | | | | l | | |
| Census: | | | | Exmpt | | |
| Flood Haz: | | | | | | |
| D | | | | Topo | | |
| s | | | | Street | 1 | PAVED |
| t | | | | Traffic | 4 | MEDIUM |

LAND SECTION (First 7 lines only)

| Use Code | Description | LUC Fact | No of Units | Depth / PriceUnits | Unit Type | Land Type | LT Factor | Base Value | Unit Price | Adj | Neigh | Neigh Infru | Neigh Mod | Infl 1 | % | Infl 2 | % | Infl 3 | % | Appraised Value | Alt Class | % | Spec Land | J Code | Fact | Use Value | Notes |
|----------|-------------|----------|-------------|--------------------|-----------|-------------|-----------|------------|------------|-------|-------|-------------|-----------|--------|---|--------|---|--------|---|-----------------|-----------|---|-----------|--------|------|-----------|-------|
| 101 | ONE FAM | | 80000 | | SQUARE FE | PRIME SITE | | 0 | 10. | 1.000 | R5 | | | | | | | | | 800,000 | | | | | | 800,000 | |
| 101 | ONE FAM | | 0.013 | | ACRES | EXCESS ACRE | | 0 | 30,000. | 1.000 | R5 | | | | | | | | | 390 | | | | | | 400 | |

IN PROCESS APPRAISAL SUMMARY

| Use Code | Building Value | Yard Items | Land Size | Land Value | Total Value |
|--------------|-----------------|--------------------------------|-----------|------------|-------------|
| 101 | 1,567,300 | | 1.850 | 800,400 | 2,367,700 |
| Total Card | 1,567,300 | | 1.850 | 800,400 | 2,367,700 |
| Total Parcel | 1,567,300 | | 1.850 | 800,400 | 2,367,700 |
| Source: | Market Adj Cost | Total Value per SQ unit /Card: | 307.09 | /Parcel: | 307.09 |

| Legal Description | User Acct |
|-------------------|-----------|
| | |
| | |
| | |
| Entered Lot Size | |
| Total Land: | |
| Land Unit Type: | |

| |
|-----------|
| GIS Ref |
| GIS Ref |
| Insp Date |
| 06/30/07 |

PREVIOUS ASSESSMENT

| Tax Yr | Use | Cat | Bldg Value | Yrd Items | Land Size | Land Value | Total Value | Asses'd Value | Notes | Date |
|--------|-----|-----|------------|-----------|-----------|------------|-------------|---------------|-------------------------|------------|
| 2020 | 101 | FV | 1,701,400 | 0 | 1.85 | 800,400 | 2,501,800 | 2,501,800 | Year End Roll | 9/26/2019 |
| 2019 | 101 | FV | 1,782,300 | 0 | 1.85 | 797,200 | 2,579,500 | 2,579,500 | Create Final value 2019 | 6/4/2019 |
| 2018 | 101 | FV | 1,782,300 | 0 | 1.85 | 797,200 | 2,579,500 | 2,579,500 | Year End Roll | 9/28/2017 |
| 2017 | 101 | FV | 1,670,800 | 0 | 1.85 | 797,200 | 2,468,000 | 2,468,000 | Year End Roll | 9/29/2016 |
| 2016 | 101 | FV | 1,643,900 | 0 | 1.85 | 745,200 | 2,389,100 | 2,389,100 | Year End Roll | 1/14/2016 |
| 2015 | 101 | FV | 1,600,800 | 0 | 1.85 | 690,000 | 2,290,800 | 2,290,800 | Year End | 10/2/2014 |
| 2014 | 101 | FV | 1,485,900 | 0 | 1.85 | 680,400 | 2,166,300 | 2,166,300 | Year End Roll | 1/23/2014 |
| 2013 | 101 | FV | 1,457,100 | 0 | 1.85 | 660,400 | 2,117,500 | 2,117,500 | Year End Roll | 10/25/2012 |

SALES INFORMATION

| Grantor | Legal Ref | Type | Date | Sale Code | Sale Price | V | Tst | Verif | Assoc PCL Value | Notes |
|----------|-----------|------|-----------|-------------|------------|----|-----|-------|-----------------|-------|
| F.D.I.C. | 22448-457 | | 9/30/1992 | FORECLOSURE | 750000 | No | No | | | |

BUILDING PERMITS

| Date | Number | Descp | Amount | C/O | Last Visit | Fed Code | F. Descp | Comment |
|-----------|---------|----------|---------|-----|------------|----------|----------|-------------------|
| 11/4/2010 | 4600 | RENOVATI | 70,000 | C | 5/31/2012 | | | interior basement |
| 5/5/1997 | 1177 | ROOF | | 1 | 5/27/1997 | | | 3/25/98 100% |
| 7/30/1996 | 1011-96 | RENO-GAR | 120,000 | C | 6/6/2000 | | | 6/6/00 100% |
| 3/6/1996 | 911-96 | DEMOLITI | | C | 6/14/1996 | | | |
| 7/13/1993 | 283 | RENOVATI | 150,000 | C | 12/28/1993 | | | |

ACTIVITY INFORMATION

| Date | Result | By | Name |
|-----------|--------------|-----|------------|
| 5/31/2012 | PERMIT VISIT | 25 | D ERSKINE |
| 6/30/2007 | MEAS/EXT INS | 616 | D MANZELLO |
| 6/6/2000 | MEAS/EXT INS | 608 | |
| 5/15/2000 | MEAS+INSPCTD | 611 | |
| 6/9/1999 | MEAS+INSPCTD | 602 | |
| 2/27/1999 | MEAS+INSPCTD | 602 | |
| 3/25/1998 | MEAS/EXT INS | 602 | |
| 5/27/1997 | MEAS+INSPCTD | 602 | |
| 1/27/1996 | MEAS+INSPCTD | 606 | |

Sign: VERIFICATION OF VISIT NOT DATA

GENERAL INFORMATION

| | | |
|---------------|---|----------------|
| Type: | 9 | - CONTEMPORARY |
| Sty Ht: | 2 | - 2 |
| (Liv) Units: | 1 | Total: 1 |
| Foundation: | 1 | - CONCRETE |
| Frame: | 1 | - WOOD |
| Prime Wall: | 1 | - WOOD SHING |
| Sec Wall: | | % |
| Roof Struct: | 1 | - GABLE |
| Roof Cover: | 6 | - WOODSHINGL |
| Color: | | |
| View / Desir: | | |

GENERAL INFORMATION

| | | | |
|---------------|------|-------------|--|
| Grade: | A+ | - EXCELLENT | |
| Year Blt: | 1990 | Eff Yr Blt: | |
| Alt LUC: | | Alt %: | |
| Jurisdct: | | Fact: | |
| Const Mod: | | | |
| Lump Sum Adj: | | | |

INTERIOR INFORMATION

| | | | |
|---------------|-----|--------------|-----|
| Avg Ht/FL: | STD | | |
| Prim Int Wal: | 2 | - PLASTER | |
| Sec Int Wall: | | % | |
| Partition: | T | - TYPICAL | |
| Prim Floors: | 3 | - HARDWOOD | |
| Sec Floors: | 6 | - CERAMIC T | 5% |
| Bsmnt Flr: | | | |
| Bsmnt Gar: | | | |
| Electric: | 3 | - TYPICAL | |
| Insulation: | 2 | - TYPICAL | |
| Int vs Ext: | S | | |
| Heat Fuel: | 1 | - OIL | |
| Heat Type: | 1 | - FORCED H/A | |
| # Heat Sys: | 1 | | |
| % Heated: | 100 | % AC: | 100 |
| Solar HW: | NO | Central Vac: | NO |
| % Com Wal: | 0 | % Sprinkled: | 0 |

| | |
|--------------------|------------|
| Basic \$ / SQ: | 94.00 |
| Size Adj.: | 0.84237874 |
| Const Adj.: | 1.03121006 |
| Adj \$ / SQ: | 81.655 |
| Other Features: | 117199 |
| Grade Factor: | 2.40 |
| Neighborhood Inf: | 1.00000000 |
| LUC Factor: | 1.00 |
| Adj Total: | 1892536 |
| Depreciation: | 329301 |
| Depreciated Total: | 1563235 |

SPEC FEATURES/YARD ITEMS

| Code | Description | A | Y/S | Qty | Size/Dim | Qual | Con | Year | Unit Price | D/S | Dep | LUC | Fact | NB Fa | Appr Value | JCod | JFact | Juris. Value |
|------|-------------|---|-----|-----|----------|------|-----|------|------------|-----|-----|----------|------|-------|------------|------|-------|--------------|
| 96 | WHIRL PL | M | S | 1 | 2 | | A | AV | 1990 | | | 2,500.00 | B | 17.4 | 101 | | | 4,100 |

More: N Total Yard Items: Total Special Features: 4,100 Total: 4,100

BATH FEATURES

| | | | |
|------------|---|---------|---------|
| Full Bath: | 4 | Rating: | AVERAGE |
| A Bath: | | Rating: | |
| 3/4 Bath: | | Rating: | |
| A 3QBth: | | Rating: | |
| 1/2 Bath: | 4 | Rating: | AVERAGE |
| A HBth: | | Rating: | |
| OthrFix: | 7 | Rating: | AVERAGE |

OTHER FEATURES

| | | | |
|---------|---|---------|-----------|
| Kits: | 1 | Rating: | VERY GOOD |
| A Kits: | | Rating: | |
| Frpl: | 3 | Rating: | AVERAGE |
| WSFlue: | | Rating: | |

CONDO INFORMATION

| | |
|--------------|--|
| Location: | |
| Total Units: | |
| Floor: | |
| % Own: | |
| Name: | |

DEPRECIATION

| | | | |
|-------------|----|-----------|-------|
| Phys Cond: | AV | - Average | 17.0% |
| Functional: | | | % |
| Economic: | | | % |
| Special: | | | % |
| Override: | | | % |
| Total: | | | 17.4% |

CALC SUMMARY

| | |
|--------------------|------------|
| Basic \$ / SQ: | 94.00 |
| Size Adj.: | 0.84237874 |
| Const Adj.: | 1.03121006 |
| Adj \$ / SQ: | 81.655 |
| Other Features: | 117199 |
| Grade Factor: | 2.40 |
| Neighborhood Inf: | 1.00000000 |
| LUC Factor: | 1.00 |
| Adj Total: | 1892536 |
| Depreciation: | 329301 |
| Depreciated Total: | 1563235 |

COMMENTS

SWAP OF LAND-124-16-8 + 124-16-9
BK.22448,PGS.452 + 455 9/92 PLAN RECORDED
8-27-92 #700.

RESIDENTIAL GRID

| | | | | | | | | | | | | |
|--------------|-------|--------|---------|---|--------|----|-----|----|----|----|---|---|
| 1st Res Grid | Desc: | Line 1 | # Units | 1 | | | | | | | | |
| Level | FY | LR | DR | D | K | FR | RR | BR | FB | HB | L | O |
| Other | | | | | | | | | | | | |
| Upper | | | | | | | | | | | | |
| Lvl 2 | | | | | | | | | | | | |
| Lvl 1 | | | | | | | | | | | | |
| Lower | | | | | | | | | | | | |
| Totals | RM: | 10 | BR: | 4 | Baths: | 4 | HB: | 4 | | | | |

REMODELING

| | |
|------------|------|
| Exterior: | |
| Interior: | 1999 |
| Additions: | |
| Kitchen: | |
| Baths: | |
| Plumbing: | |
| Electric: | |
| Heating: | |
| General: | |

RES BREAKDOWN

| No Unit | RMS | BRS | FL |
|---------|-----|-----|----|
| 1 | 10 | 4 | |
| Totals | | | |
| 1 | 10 | 4 | |

COMPARABLE SALES

| Rate | Parcel ID | Typ | Date | Sale Price |
|-------------------|-----------|--------------|--------|---------------------|
| | | | | |
| | | | | |
| | | | | |
| | | | | |
| | | | | |
| WtAv\$/SQ: | | AvRate: | | Ind.Val 2391165.738 |
| Juris. Factor: | | Val/Su Fin: | 203.28 | |
| Special Features: | 4100 | Val/Su Net: | 141.54 | |
| Final Total: | 1567300 | Val/Su SzAd: | 241.31 | |

PARCEL ID

| | | | | |
|---------|------------|------|-------|--------------|
| 190 1 0 | Appr Value | JCod | JFact | Juris. Value |
| | | | | |

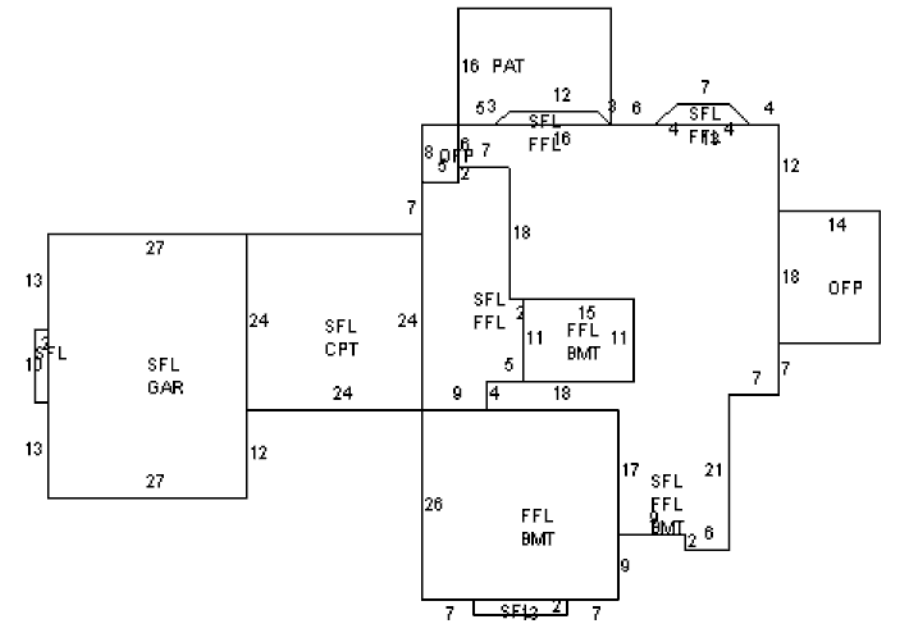
SKETCH**SUB AREA**

| Code | Description | Area - SQ | Rate - AV | Undepr Value | |
|--------------------|-------------|------------|-----------|--------------|------|
| SFL | 2ND FLOOR | 3,611 | 81.650 | 294,856 | |
| FFL | 1ST FLOOR | 2,884 | 81.650 | 235,493 | |
| BMT | BASEMENT | 2,430 | 35.720 | 86,809 | |
| GAR | GARAGE | 972 | 36.000 | 34,992 | |
| CPT | CARPORT | 576 | 22.000 | 12,672 | |
| PAT | PATIO | 308 | 7.000 | 2,156 | |
| OFF | OPEN PORCH | 292 | 15.000 | 4,380 | |
| Net Sketched Area: | | 11,073 | Total: | 671,358 | |
| Size Ad | 6495 | Gross Area | 11073 | FinArea | 7710 |

SUB AREA DETAIL

| Sub Area | % Usbl | Descrip | % Type | Qu | # Ten |
|----------|--------|---------|--------|----|-------|
| BMT | 100 | FLA | 50 | A | 0 |

IMAGE

AssessPro Patriot Properties, Inc