



PROPERTY LOCATION

No	Alt No	Direction/Street/City
5		BOYCE FARM RD, LINCOLN

OWNERSHIP

Owner 1:	ALTMAN JULIA G
Owner 2:	ALTMAN SYLVIA I
Owner 3:	
Street 1:	5 BOYCE FARM RD
Street 2:	
Twn/City:	LINCOLN
St/Prov:	MA Cntry Own Occ: Y
Postal:	01773 Type:

PREVIOUS OWNER

Owner 1:	HARVEY FRANK L -
Owner 2:	HARVEY ADELE P -
Street 1:	6254 WILLOWGATE LANE
Twn/City:	DALLAS
St/Prov:	TX Cntry
Postal:	75230

NARRATIVE DESCRIPTION

This Parcel contains 1.96 ACRES of land mainly classified as ONE FAM with a(n) CONTEMPORARY Building Built about 1965, Having Primarily WOOD Exterior and TAR+GRAVEL Roof Cover, with 1 Units, 3 Baths, 0 HalfBaths, 0 3/4 Baths, 12 Rooms, and 5 Bdrms.

OTHER ASSESSMENTS

Code	Descrip/No	Amount	Com. Int

PROPERTY FACTORS

Item	Code	Descp	%	Item	Code	Descp
Z	R1	Residential	100	U	A	SEPTIC
o				t		
n				l		
Census:				Exmpt		
Flood Haz:						
D				Topo		
s				Street	1	PAVED
t				Traffic	4	MEDIUM

LAND SECTION (First 7 lines only)

Use Code	Description	LUC Fact	No of Units	Depth / PriceUnits	Unit Type	Land Type	LT Factor	Base Value	Unit Price	Adj	Neigh	Neigh Infl	Neigh Mod	Infl 1	%	Infl 2	%	Infl 3	%	Appraised Value	Alt Class	%	Spec Land	J Code	Fact	Use Value	Notes
101	ONE FAM		80000		SQUARE FE	PRIME SITE		0	7.91	1.000	R3									632,800						632,800	
101	ONE FAM		0.123		ACRES	EXCESS ACRE		0	30,000.	1.000	R3									3,690						3,700	

IN PROCESS APPRAISAL SUMMARY

Use Code	Building Value	Yard Items	Land Size	Land Value	Total Value	Legal Description
101	523,200	600	1.960	636,500	1,160,300	2718
Total Card						Entered Lot Size
Total Parcel						Total Land:
Source: Market Adj Cost						Land Unit Type:
Total Value per SQ unit /Card: 280.67						/Parcel: 280.67

PREVIOUS ASSESSMENT

Tax Yr	Use	Cat	Bldg Value	Yrd Items	Land Size	Land Value	Total Value	Asses'd Value	Notes	Date
2021	101	FV	510,000	600	1.96	563,700	1,074,300	1,074,300	Year End Roll	10/15/2020
2020	101	FV	502,200	600	1.96	563,700	1,066,500	1,066,500	Year End Roll	9/26/2019
2019	101	FV	494,300	600	1.96	546,100	1,041,000	1,041,000	Create Final value 2019	6/4/2019
2018	101	FV	494,300	600	1.96	546,100	1,041,000	1,041,000	Year End Roll	9/28/2017
2017	101	FV	486,500	600	1.96	515,700	1,002,800	1,002,800	Year End Roll	9/29/2016
2016	101	FV	482,600	600	1.96	500,500	983,700	983,700	Year End Roll	1/14/2016
2015	101	FV	470,900	600	1.96	463,700	935,200	935,200	Year End	10/2/2014
2014	101	FV	439,700	600	1.96	415,700	856,000	856,000	Year End Roll	1/23/2014

SALES INFORMATION

Grantor	Legal Ref	Type	Date	Sale Code	Sale Price	V	Tst	Verif	Assoc PCL Value	Notes
HARVEY FRANK L,	1221-195		5/18/2000		640,000	No	No			
FLEMING WILLIAM	905-25		6/2/1978		163,500	No	No			

BUILDING PERMITS

Date	Number	Descp	Amount	C/O	Last Visit	Fed Code	F. Descp	Comment
8/16/2011	4826	RENOVATI	55,630	C	6/7/2012			repair & replace d
11/4/2010	4599	MANUAL	16,800	C	7/6/2011			underpin approxima
11/24/2004	3092	RENOVATI	25,000	C	6/4/2005			garage to living s
6/6/2000	1997	RENOVATI	35,000	C	7/6/2001			REMODEL KITCHEN AN
6/6/2000	1995	ROOF		C	7/6/2001			

ACTIVITY INFORMATION

Date	Result	By	Name
6/7/2012	MEAS/EXT INS	25	D ERSKINE
7/6/2011	MEAS/EXT INS	25	D ERSKINE
11/13/2008	MEAS/EXT INS	25	D ERSKINE
6/4/2005	MEAS+INSPECTD	615	
7/6/2001	MEAS/EXT INS	613	
10/30/1995	MEAS+INSPECTD	607	
11/8/1991	INSPECTED	601	

Sign: VERIFICATION OF VISIT NOT DATA

EXTERIOR INFORMATION

Type:	9 - CONTEMPORARY
Sty Ht:	1 - 1
(Liv) Units:	1 Total: 1
Foundation:	6 - SLAB
Frame:	1 - WOOD
Prime Wall:	26 - WOOD
Sec Wall:	%
Roof Struct:	1 - GABLE
Roof Cover:	4 - TAR+GRAVEL
Color:	
View / Desir:	

GENERAL INFORMATION

Grade:	B- - GOOD (-)		
Year Blt:	1965	Eff Yr Blt:	
Alt LUC:		Alt %:	
Jurisdct:		Fact:	
Const Mod:			
Lump Sum Adj:			

BATH FEATURES

Full Bath:	3	Rating:	GOOD
A Bath:		Rating:	
3/4 Bath:		Rating:	
A 3QBth:		Rating:	
1/2 Bath:		Rating:	
A HBth:		Rating:	
OthrFix:	1	Rating:	AVERAGE

OTHER FEATURES

Kits:	2	Rating:	GOOD
A Kits:		Rating:	
Frpl:	2	Rating:	AVERAGE
WSFlue:		Rating:	

COMMENTS

FFL ANGLED AT GAR .

RESIDENTIAL GRID

1st Res Grid Desc:	Line 1	# Units:	1									
Level	FY	LR	DR	D	K	FR	RR	BR	FB	HB	L	O
Other												
Upper												
Lvl 2												
Lvl 1												
Lower												
Totals												

CONDO INFORMATION

Location:	
Total Units:	
Floor:	1 - 1ST FLOOR
% Own:	
Name:	

REMODELING

Exterior:	
Interior:	
Additions:	
Kitchen:	
Baths:	
Plumbing:	
Electric:	
Heating:	
General:	

RES BREAKDOWN

No Unit	RMS	BRS	FL
1	12	5	1
Totals			
1	12	5	1

SKETCH

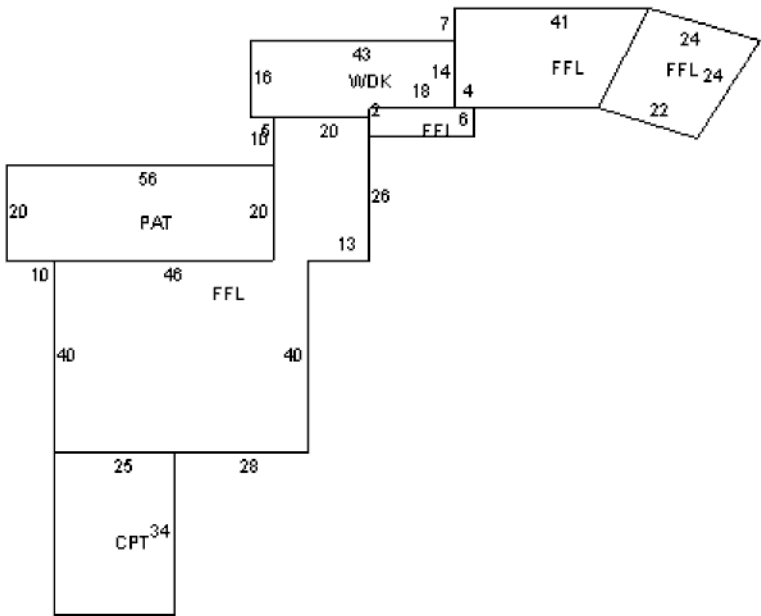

INTERIOR INFORMATION

Avg Ht/FL:	STD		
Prim Int Wal:	1 - DRYWALL		
Sec Int Wall:	%		
Partition:	T - TYPICAL		
Prim Floors:	4 - CARPET		
Sec Floors:	3 - HARDWOOD 40%		
Bsmnt Flr:			
Bsmnt Gar:			
Electric:	3 - TYPICAL		
Insulation:	2 - TYPICAL		
Int vs Ext:	S		
Heat Fuel:	2 - GAS		
Heat Type:	1 - FORCED H/A		
# Heat Sys:	1		
% Heated:	100	% AC:	50
Solar HW:	NO	Central Vac:	NO
% Com Wal:	0	% Sprinkled:	0

DEPRECIATION

Phys Cond:	VG - Very Good	13.8%
Functional:		%
Economic:		%
Special:		%
Override:		%
Total:		13.8%

CALC SUMMARY

Basic \$ / SQ:	104.00
Size Adj.:	0.89513791
Const Adj.:	0.97776002
Adj \$ / SQ:	91.024
Other Features:	92223
Grade Factor:	1.20
Neighborhood Inf:	1.00000000
LUC Factor:	1.00
Adj Total:	606927
Depreciation:	83756
Depreciated Total:	523171

COMPARABLE SALES

Rate	Parcel ID	Typ	Date	Sale Price
WtAv\$/SQ:		AvRate:	Ind.Val	910906.0241
Juris. Factor:		Before Depr:	109.23	
Special Features:	0	Val/Su Net:	77.44	
Final Total:	523200	Val/Su SzAd:	126.56	

SUB AREA

Code	Description	Area - SQ	Rate - AV	Undepr Value	
FFL	1ST FLOOR	4,134	91.020	376,293	
PAT	PATIO	1,120	7.000	7,840	
CPT	CARPORT	850	22.000	18,700	
WDK	WOOD DECK	652	16.440	10,716	
Net Sketched Area:		6,756	Total:	413,549	
Size Ad	4134	Gross Area	6756	FinArea	4134

SUB AREA DETAIL

Sub Area	% Usbl	Descrip	% Type	Qu	# Ten

SPEC FEATURES/YARD ITEMS

Code	Description	A	Y/S	Qty	Size/Dim	Qual	Con	Year	Unit Price	D/S	Dep	LUC	Fact	NB Fa	Appr Value	JCod	JFact	Juris. Value
2	SHED/FR	D	Y	1	128	A	AV	1965	15.00	T	70	101			600			600

PARCEL ID 179 26 0

More:	N	Total Yard Items:	600	Total Special Features:		Total:	600
-------	---	-------------------	-----	-------------------------	--	--------	-----

IMAGE

AssessPro Patriot Properties, Inc

