



**PROPERTY LOCATION**

| No | Alt No | Direction/Street/City |
|----|--------|-----------------------|
| 90 |        | CONANT RD, LINCOLN    |

**OWNERSHIP**

|           |                         |
|-----------|-------------------------|
| Owner 1:  | TRANCHINO JESSICA W     |
| Owner 2:  | TRANCHINO CHRISTOPHER G |
| Owner 3:  |                         |
| Street 1: | 90 CONANT RD            |
| Street 2: |                         |
| Twn/City: | LINCOLN                 |
| St/Prov:  | MA Cntry Own Occ: Y     |
| Postal:   | 01773-3913 Type:        |

**PREVIOUS OWNER**

|           |                      |
|-----------|----------------------|
| Owner 1:  | DOYLE - KATHRYN NEAL |
| Owner 2:  | -                    |
| Street 1: | 90 CONANT RD         |
| Twn/City: | LINCOLN              |
| St/Prov:  | MA Cntry             |
| Postal:   | 01773-3913           |

**NARRATIVE DESCRIPTION**

This Parcel contains 1.86 ACRES of land mainly classified as ONE FAM with a(n) CONVENT'NL Building Built about 1920, Having Primarily WOOD SHING Exterior and ASPHALT Roof Cover, with 1 Units, 3 Baths, 2 HalfBaths, 0 3/4 Baths, 11 Rooms, and 4 Bdrms.

**OTHER ASSESSMENTS**

| Code | Descrip/No | Amount | Com. Int |
|------|------------|--------|----------|
|      |            |        |          |

**PROPERTY FACTORS**

| Item       | Code | Descp       | %   | Item    | Code | Descp  |
|------------|------|-------------|-----|---------|------|--------|
| Z          | R1   | Residential | 100 | U       | A    | SEPTIC |
| o          |      |             |     | t       |      |        |
| n          |      |             |     | l       |      |        |
| Census:    |      |             |     | Exmpt   |      |        |
| Flood Haz: |      |             |     |         |      |        |
| D          |      |             |     | Topo    |      |        |
| s          |      |             |     | Street  | 1    | PAVED  |
| t          |      |             |     | Traffic | 4    | MEDIUM |

**LAND SECTION (First 7 lines only)**

| Use Code | Description | LUC Fact | No of Units | Depth / PriceUnits | Unit Type | Land Type   | LT Factor | Base Value | Unit Price | Adj   | Neigh | Neigh Infl | Neigh Mod | Infl 1 | % | Infl 2 | % | Infl 3 | % | Appraised Value | Alt Class | % | Spec Land | J Code | Fact | Use Value | Notes   |
|----------|-------------|----------|-------------|--------------------|-----------|-------------|-----------|------------|------------|-------|-------|------------|-----------|--------|---|--------|---|--------|---|-----------------|-----------|---|-----------|--------|------|-----------|---------|
| 101      | ONE FAM     |          | 80000       |                    | SQUARE FE | PRIME SITE  |           | 0          | 8.75       | 1.000 | R3    |            |           |        |   |        |   |        |   | 700,000         |           |   |           |        |      | 700,000   |         |
| 101      | ONE FAM     |          | 0.013       |                    | ACRES     | EXCESS ACRE |           | 0          | 30,000.    | 1.000 | R3    |            |           |        |   |        |   |        |   | 390             |           |   |           |        |      | 400       |         |
| 101      | ONE FAM     |          | 0.01        |                    | ACRES     | UNDEV       | 0.2       | 0          | 30,000.    | 0.200 | R3    |            |           |        |   |        |   |        |   | 60              |           |   |           |        |      | 100       | Wetland |

**IN PROCESS APPRAISAL SUMMARY**

| Use Code                              | Building Value | Yard Items | Land Size | Land Value | Total Value | Legal Description | User Acct |
|---------------------------------------|----------------|------------|-----------|------------|-------------|-------------------|-----------|
| 101                                   | 961,700        | 600        | 1.860     | 700,500    | 1,662,800   |                   |           |
| Total Card                            |                |            |           |            |             | Entered Lot Size  |           |
| Total Parcel                          |                |            |           |            |             | Total Land:       |           |
| Source: Market Adj Cost               |                |            |           |            |             | Land Unit Type:   |           |
| Total Value per SQ unit /Card: 364.12 |                |            |           |            |             | /Parcel: 364.12   |           |

**PREVIOUS ASSESSMENT**

| Tax Yr | Use | Cat | Bldg Value | Yrd Items | Land Size | Land Value | Total Value | Asses'd Value | Notes                   | Date       |
|--------|-----|-----|------------|-----------|-----------|------------|-------------|---------------|-------------------------|------------|
| 2022   | 101 | FV  | 874,900    | 900       | 1.86      | 633,300    | 1,509,100   | 1,509,100     | Year End Roll           | 10/19/2021 |
| 2021   | 101 | FV  | 799,200    | 900       | 1.86      | 560,500    | 1,360,600   | 1,360,600     | Year End Roll           | 10/15/2020 |
| 2020   | 101 | FV  | 748,800    | 900       | 1.86      | 560,500    | 1,310,200   | 1,310,200     | Year End Roll           | 9/26/2019  |
| 2019   | 101 | FV  | 728,100    | 900       | 1.86      | 542,900    | 1,271,900   | 1,271,900     | Create Final value 2019 | 6/4/2019   |
| 2018   | 101 | FV  | 597,000    | 900       | 1.86      | 542,900    | 1,140,800   | 1,140,800     | Year End Roll           | 9/28/2017  |
| 2017   | 101 | FV  | 571,100    | 900       | 1.86      | 512,500    | 1,084,500   | 1,084,500     | Year End Roll           | 9/29/2016  |
| 2016   | 101 | FV  | 549,800    | 900       | 1.86      | 497,300    | 1,048,000   | 1,048,000     | Year End Roll           | 1/14/2016  |
| 2015   | 101 | FV  | 529,500    | 900       | 1.86      | 460,500    | 990,900     | 990,900       | Year End                | 10/2/2014  |

**SALES INFORMATION**

| Grantor          | Legal Ref | Type | Date       | Sale Code | Sale Price | V  | Tst | Verif | Assoc PCL Value | Notes |
|------------------|-----------|------|------------|-----------|------------|----|-----|-------|-----------------|-------|
| DOYLE, KATHRYN N | 73484-315 |      | 10/18/2019 |           | 1,360,000  | No | No  |       |                 |       |
| WOLFF JR, JAMES  | 69828-535 |      | 8/25/2017  |           | 1,375,000  | No | No  |       |                 |       |
| DAVIS PRESCOTT   | 16075-475 |      | 3/28/1985  |           | 235,000    | No | No  |       |                 |       |

**BUILDING PERMITS**

| Date      | Number | Descp    | Amount  | C/O | Last Visit | Fed Code | F. Descp | Comment           |
|-----------|--------|----------|---------|-----|------------|----------|----------|-------------------|
| 9/3/2015  | 6218   | ROOF     | 21,950  | C   |            |          |          | Strip and re-roof |
| 5/6/2008  | 3934   | TEMPORAR |         | C   |            |          |          | tent 5-16 to 5-19 |
| 12/4/2002 | 2623   | RENOVATI | 51,500  | C   | 6/27/2003  |          |          | 2 bathrooms       |
| 5/8/1998  | 1413   | ADDITION | 215,000 | C   | 6/4/1998   |          |          |                   |

**ACTIVITY INFORMATION**

| Date       | Result       | By  | Name      |
|------------|--------------|-----|-----------|
| 10/30/2018 | MEAS/EXT INS | 622 | K Cuoco   |
| 10/8/2009  | MEAS/EXT INS | 25  | D ERSKINE |
| 6/27/2003  | MEAS/EXT INS | 615 |           |
| 6/30/1999  | MEAS/EXT INS | 602 |           |
| 3/6/1999   | MEAS+INSPCTD | 602 |           |
| 6/4/1998   | MEAS/EXT INS | 602 |           |
| 11/17/1995 | MEAS+INSPCTD | 607 |           |
| 12/13/1988 | INSPECTED    | 601 |           |

Sign: VERIFICATION OF VISIT NOT DATA

**EXTERIOR INFORMATION**

|               |    |        |              |
|---------------|----|--------|--------------|
| Type:         | 22 | -      | CONVENT'NL   |
| Sty Ht:       | 2A | -      | 2A           |
| (Liv) Units:  | 1  | Total: | 1            |
| Foundation:   | 3  | -      | BRK OR STN   |
| Frame:        | 1  | -      | WOOD         |
| Prime Wall:   | 1  | -      | WOOD SHING   |
| Sec Wall:     | 2  | -      | CLAPBOAR 25% |
| Roof Struc:   | 2  | -      | HIP          |
| Roof Cover:   | 1  | -      | ASPHALT      |
| Color:        |    |        |              |
| View / Desir: |    |        |              |

**GENERAL INFORMATION**

|               |      |             |          |
|---------------|------|-------------|----------|
| Grade:        | B+   | -           | GOOD (+) |
| Year Blt:     | 1920 | Eff Yr Blt: | 1998     |
| Alt LUC:      |      | Alt %:      |          |
| Jurisdict:    |      | Fact:       |          |
| Const Mod:    |      |             |          |
| Lump Sum Adj: |      |             |          |

**INTERIOR INFORMATION**

|               |                |              |    |
|---------------|----------------|--------------|----|
| Avg Ht/FL:    | STD            |              |    |
| Prim Int Wal: | 1 - DRYWALL    |              |    |
| Sec Int Wall: | %              |              |    |
| Partition:    | T - TYPICAL    |              |    |
| Prim Floors:  | 3 - HARDWOOD   |              |    |
| Sec Floors:   | %              |              |    |
| Bsmnt Flr:    |                |              |    |
| Bsmnt Gar:    |                |              |    |
| Electric:     | 3 - TYPICAL    |              |    |
| Insulation:   | 2 - TYPICAL    |              |    |
| Int vs Ext:   | S              |              |    |
| Heat Fuel:    | 1 - OIL        |              |    |
| Heat Type:    | 3 - FORCED H/W |              |    |
| # Heat Sys:   | 1              |              |    |
| % Heated:     | 100            | % AC:        | 30 |
| Solar HW:     | NO             | Central Vac: | NO |
| % Com Wal:    | 0              | % Sprinkled: | 0  |

**SPEC FEATURES/YARD ITEMS**

| Code | Description | A | Y/S | Qty | Size/Dim | Qual  | Con | Year | Unit Price | D/S | Dep | LUC   | Fact | NB Fa | Appr Value | JCod | JFact | Juris. Value |
|------|-------------|---|-----|-----|----------|-------|-----|------|------------|-----|-----|-------|------|-------|------------|------|-------|--------------|
| 2    | SHED/FR     |   | D   | Y   | 1        | 12X12 | A   | AV   | 1985       |     |     | 15.00 | T    | 70    | 101        | 600  |       | 600          |

|       |   |                   |     |                         |  |        |     |
|-------|---|-------------------|-----|-------------------------|--|--------|-----|
| More: | N | Total Yard Items: | 600 | Total Special Features: |  | Total: | 600 |
|-------|---|-------------------|-----|-------------------------|--|--------|-----|

**BATH FEATURES**

|            |   |         |         |
|------------|---|---------|---------|
| Full Bath: | 3 | Rating: | GOOD    |
| A Bath:    |   | Rating: |         |
| 3/4 Bath:  |   | Rating: |         |
| A 3QBth:   |   | Rating: |         |
| 1/2 Bath:  | 2 | Rating: | AVERAGE |
| A HBth:    |   | Rating: |         |
| OthrFix:   | 2 | Rating: | AVERAGE |

**OTHER FEATURES**

|         |   |         |           |
|---------|---|---------|-----------|
| Kits:   | 1 | Rating: | VERY GOOD |
| A Kits: |   | Rating: |           |
| Frpl:   | 1 | Rating: | AVERAGE   |
| WSFlue: |   | Rating: |           |

**CONDO INFORMATION**

|              |   |   |           |
|--------------|---|---|-----------|
| Location:    |   |   |           |
| Total Units: |   |   |           |
| Floor:       | 1 | - | 1ST FLOOR |
| % Own:       |   |   |           |
| Name:        |   |   |           |

**DEPRECIATION**

|             |                |      |
|-------------|----------------|------|
| Phys Cond:  | VG - Very Good | 6.0% |
| Functional: |                | %    |
| Economic:   |                | %    |
| Special:    |                | %    |
| Override:   |                | %    |
| Total:      |                | 6%   |

**CALC SUMMARY**

|                    |            |
|--------------------|------------|
| Basic \$ / SQ:     | 125.00     |
| Size Adj.:         | 0.92311025 |
| Const Adj.:        | 1.00979996 |
| Adj \$ / SQ:       | 116.520    |
| Other Features:    | 93729      |
| Grade Factor:      | 1.60       |
| Neighborhood Inf:  | 1.00000000 |
| LUC Factor:        | 1.00       |
| Adj Total:         | 1023098    |
| Depreciation:      | 61386      |
| Depreciated Total: | 961712     |

**COMMENTS**

*(Empty comment box)*

**RESIDENTIAL GRID**

|              |       |        |         |   |        |    |     |    |    |    |   |   |
|--------------|-------|--------|---------|---|--------|----|-----|----|----|----|---|---|
| 1st Res Grid | Desc: | Line 1 | # Units | 1 |        |    |     |    |    |    |   |   |
| Level        | FY    | LR     | DR      | D | K      | FR | RR  | BR | FB | HB | L | O |
| Other        |       |        |         |   |        |    |     |    |    |    |   |   |
| Upper        |       |        |         |   |        |    |     |    |    |    |   |   |
| Lvl 2        |       |        |         |   |        |    |     |    |    |    |   |   |
| Lvl 1        |       |        |         |   |        |    |     |    |    |    |   |   |
| Lower        |       |        |         |   |        |    |     |    |    |    |   |   |
| Totals       | RM's: | 11     | BR's:   | 4 | Baths: | 3  | HB: | 2  |    |    |   |   |

**REMODELING**

|            |      |
|------------|------|
| Exterior:  |      |
| Interior:  |      |
| Additions: | 1998 |
| Kitchen:   |      |
| Baths:     |      |
| Plumbing:  |      |
| Electric:  |      |
| Heating:   |      |
| General:   |      |

**RES BREAKDOWN**

| No Unit | RMS | BRS | FL |
|---------|-----|-----|----|
| 1       | 11  | 4   |    |
| Totals  |     |     |    |
| 1       | 11  | 4   |    |

**COMPARABLE SALES**

| Rate              | Parcel ID | Typ          | Date | Sale Price |             |
|-------------------|-----------|--------------|------|------------|-------------|
|                   |           |              |      |            |             |
|                   |           |              |      |            |             |
|                   |           |              |      |            |             |
|                   |           |              |      |            |             |
|                   |           |              |      |            |             |
| WtAv\$/SQ:        |           | AvRate:      |      | Ind.Val    | 979178.6885 |
| Juris. Factor:    |           | Before Depr: |      | 186.43     |             |
| Special Features: | 0         | Val/Su Net:  |      | 149.24     |             |
| Final Total:      | 961700    | Val/Su SzAd  |      | 277.47     |             |

**SKETCH**

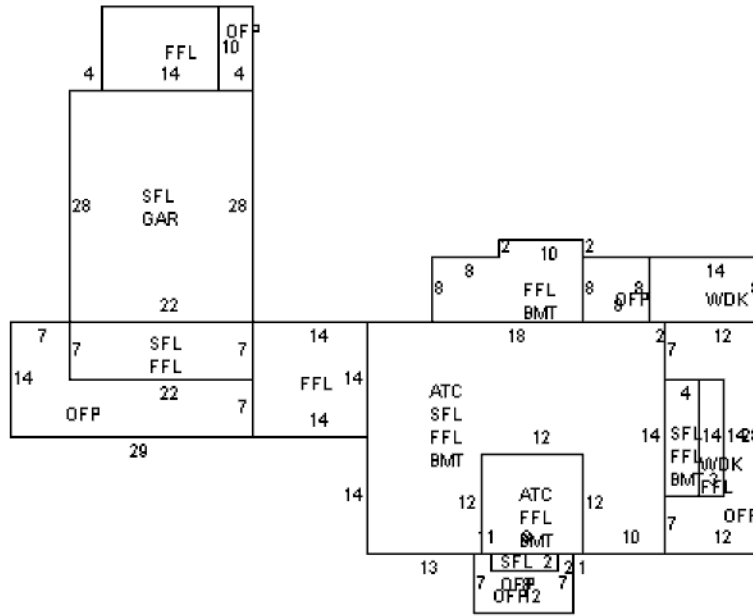

**SUB AREA**

| Code               | Description | Area - SQ  | Rate - AV | Undepr Value |      |
|--------------------|-------------|------------|-----------|--------------|------|
| FFL                | 1ST FLOOR   | 1,760      | 116.520   | 205,074      |      |
| SFL                | 2ND FLOOR   | 1,706      | 116.520   | 198,782      |      |
| BMT                | BASEMENT    | 1,228      | 57.530    | 70,649       |      |
| OPF                | OPEN PORCH  | 678        | 15.000    | 10,170       |      |
| GAR                | GARAGE      | 616        | 36.000    | 22,176       |      |
| ATC                | ATTIC       | 302        | 116.520   | 35,236       |      |
| WDK                | WOOD DECK   | 154        | 23.500    | 3,619        |      |
| Net Sketched Area: |             | 6,444      | Total:    | 545,706      |      |
| Size Ad            | 3466        | Gross Area | 7150      | FinArea      | 4567 |

**SUB AREA DETAIL**

| Sub Area | % Usbl | Descrip | % Type | Qu | # Ten |
|----------|--------|---------|--------|----|-------|
| FFL      |        |         |        |    |       |
| SFL      |        |         |        |    |       |
| BMT      | 100    | FLA     |        | 65 | A     |
| GAR      |        |         |        |    |       |
| OPF      |        |         |        |    |       |
| WDK      |        |         |        |    |       |
| ATC      |        |         |        |    |       |
| FFL      |        |         |        |    |       |
| SFL      |        |         |        |    |       |
| BMT      |        |         |        |    |       |
| FFL      |        |         |        |    |       |
| SFL      |        |         |        |    |       |
| BMT      |        |         |        |    |       |
| FFL      |        |         |        |    |       |
| OPF      |        |         |        |    |       |
| WDK      |        |         |        |    |       |
| FFL      |        |         |        |    |       |
| SFL      |        |         |        |    |       |
| BMT      |        |         |        |    |       |
| FFL      |        |         |        |    |       |
| SFL      |        |         |        |    |       |
| BMT      |        |         |        |    |       |
| FFL      |        |         |        |    |       |
| SFL      |        |         |        |    |       |
| BMT      |        |         |        |    |       |
| FFL      |        |         |        |    |       |
| SFL      |        |         |        |    |       |
| BMT      |        |         |        |    |       |
| FFL      |        |         |        |    |       |
| SFL      |        |         |        |    |       |
| BMT      |        |         |        |    |       |
| FFL      |        |         |        |    |       |
| SFL      |        |         |        |    |       |
| BMT      |        |         |        |    |       |
| FFL      |        |         |        |    |       |
| SFL      |        |         |        |    |       |
| BMT      |        |         |        |    |       |
| FFL      |        |         |        |    |       |
| SFL      |        |         |        |    |       |
| BMT      |        |         |        |    |       |
| FFL      |        |         |        |    |       |
| SFL      |        |         |        |    |       |
| BMT      |        |         |        |    |       |
| FFL      |        |         |        |    |       |
| SFL      |        |         |        |    |       |
| BMT      |        |         |        |    |       |

**IMAGE**

*AssessPro* Patriot Properties, Inc

