



PROPERTY LOCATION

No	Alt No	Direction/Street/City
26		BYPASS RD, LINCOLN

OWNERSHIP

Owner 1:	MRAKOVICH TR DAVID V
Owner 2:	MRAKOVICH TR GERTRUDE A
Owner 3:	REVOC TRUS OF DVMRAKOVICH
Street 1:	7360 55TH AVE EAST UNIT 305
Street 2:	
Twn/City:	BRADENTON
St/Prov:	FL Cntry Own Occ: Y
Postal:	34203 Type:

PREVIOUS OWNER

Owner 1:	MRAKOVICH DAVID V -
Owner 2:	MRAKOVICH GERTRUDE A -
Street 1:	26 BYPASS RD
Twn/City:	LINCOLN
St/Prov:	MA Cntry
Postal:	01773

NARRATIVE DESCRIPTION

This Parcel contains 2.2 ACRES of land mainly classified as ONE FAM with a(n) RANCH Building Built about 1959, Having Primarily CLAPBOARD Exterior and ASPHALT Roof Cover, with 1 Units, 3 Baths, 0 HalfBaths, 0 3/4 Baths, 6 Rooms, and 3 Bdrms.

OTHER ASSESSMENTS

Code	Descrip/No	Amount	Com. Int

PROPERTY FACTORS

Item	Code	Descrp	%	Item	Code	Descrp
Z	R1	Residential	100	U	A	SEPTIC
o				t		
n				l		
Census:				Exmpt		
Flood Haz:						
D				Topo		
s				Street	1	PAVED
t				Traffic	4	MEDIUM

LAND SECTION (First 7 lines only)

Use Code	Description	LUC Fact	No of Units	Depth / PriceUnits	Unit Type	Land Type	LT Factor	Base Value	Unit Price	Adj	Neigh	Neigh Infl	Neigh Mod	Infl 1	%	Infl 2	%	Infl 3	%	Appraised Value	Alt Class	%	Spec Land	J Code	Fact	Use Value	Notes
101	ONE FAM		80000		SQUARE FE	PRIME SITE		0	8.	1.000	R2									640,000						640,000	
101	ONE FAM		0.363		ACRES	EXCESS ACRE		0	30,000.	1.000	R2									10,890						10,900	

IN PROCESS APPRAISAL SUMMARY

Use Code	Building Value	Yard Items	Land Size	Land Value	Total Value	Legal Description	User Acct
101	255,900	600	2.200	650,900	907,400		
Total Card	255,900	600	2.200	650,900	907,400	Entered Lot Size	
Total Parcel	255,900	600	2.200	650,900	907,400	Total Land:	
Source:	Market Adj Cost	Total Value per SQ unit /Card:		388.21	/Parcel:	388.21	Land Unit Type:

PREVIOUS ASSESSMENT

Tax Yr	Use	Cat	Bldg Value	Yrd Items	Land Size	Land Value	Total Value	Asses'd Value	Notes	Date
2022	101	FV	223,200	600	2.2	590,900	814,700	814,700	Year End Roll	10/19/2021
2021	101	FV	205,800	600	2.2	510,900	717,300	717,300	Year End Roll	10/15/2020
2020	101	FV	204,000	600	2.2	518,900	723,500	723,500	Year End Roll	9/26/2019
2019	101	FV	186,600	600	2.2	502,100	689,300	689,300	Create Final value 2019	6/4/2019
2018	101	FV	186,600	600	2.2	502,100	689,300	689,300	Year End Roll	9/28/2017
2017	101	FV	184,900	600	2.2	487,700	673,200	673,200	Year End Roll	9/29/2016
2016	101	FV	183,100	600	2.2	487,700	671,400	671,400	Year End Roll	1/14/2016
2015	101	FV	179,700	600	2.2	414,900	595,200	595,200	Year End	10/2/2014

SALES INFORMATION

Grantor	Legal Ref	Type	Date	Sale Code	Sale Price	V	Tst	Verif	Assoc PCL Value	Notes
MRAKOVICH DAVID	54768-476		6/2/2010	FAMILY	100	No	No			
MCGRATH, JAMES	11582-454		10/1/1968		45,000	No	No			

BUILDING PERMITS

Date	Number	Descrp	Amount	C/O	Last Visit	Fed Code	F. Descrp	Comment
8/27/2013	5532	DEMOLITI		C	5/20/2014			demo inground pool

ACTIVITY INFORMATION

Date	Result	By	Name
5/20/2014	MEAS/EXT INS	25	D ERSKINE
10/27/2009	MEAS/EXT INS	25	D ERSKINE
11/20/2004	M&L COMPLETE	615	
12/21/1995	MEAS+INSPCTD	606	

Sign: VERIFICATION OF VISIT NOT DATA

EXTERIOR INFORMATION

Type:	19 - RANCH		
Sty Ht:	1 - 1		
(Liv) Units:	1	Total:	1
Foundation:	1 - CONCRETE		
Frame:	1 - WOOD		
Prime Wall:	2 - CLAPBOARD		
Sec Wall:	16 - STONE VE	25%	
Roof Struct:	1 - GABLE		
Roof Cover:	1 - ASPHALT		
Color:			
View / Desir:			

GENERAL INFORMATION

Grade:	C - AVERAGE		
Year Blt:	1959	Eff Yr Blt:	
Alt LUC:		Alt %:	
Jurisdict:		Fact.:	
Const Mod:			
Lump Sum Adj:			

INTERIOR INFORMATION

Avg Ht/FL:	STD		
Prim Int Wal:	2 - PLASTER		
Sec Int Wall:			
Partition:	T - TYPICAL		
Prim Floors:	3 - HARDWOOD		
Sec Floors:			
Bsmnt Flr:			
Bsmnt Gar:			
Electric:	3 - TYPICAL		
Insulation:	2 - TYPICAL		
Int vs Ext:	S		
Heat Fuel:	1 - OIL		
Heat Type:	3 - FORCED H/W		
# Heat Sys:	1		
% Heated:	100	% AC:	0
Solar HW:	NO	Central Vac:	NO
% Com Wal:	0	% Sprinkled:	0

SPEC FEATURES/YARD ITEMS

Code	Description	A	Y/S	Qty	Size/Dim	Qual	Con	Year	Unit Price	D/S	Dep	LUC	Fact	NB Fa	Appr Value	JCod	JFact	Juris. Value
2	SHED/FR	D	Y	1	8X10	A	AV	1970	15.00	T	70	101			400			400
2	SHED/FR	D	Y	1	6X8	A	AV	1970	15.00	T	70	101			200			200

More:	N	Total Yard Items:	600	Total Special Features:		Total:	600
-------	---	-------------------	-----	-------------------------	--	--------	-----

BATH FEATURES

Full Bath:	3	Rating:	AVERAGE
A Bath:		Rating:	
3/4 Bath:		Rating:	
A 3QBth:		Rating:	
1/2 Bath:		Rating:	
A HBth:		Rating:	
OthrFix:	1	Rating:	AVERAGE

OTHER FEATURES

Kits:	1	Rating:	AVERAGE
A Kits:		Rating:	
FrpI:	2	Rating:	AVERAGE
WSFlue:	1	Rating:	AVERAGE

CONDO INFORMATION

Location:	
Total Units:	
Floor:	1 - 1ST FLOOR
% Own:	
Name:	

DEPRECIATION

Phys Cond:	AV - Average	31.0%
Functional:		%
Economic:		%
Special:		%
Override:		%
Total:		31.5%

CALC SUMMARY

Basic \$ / SQ:	118.00
Size Adj.:	1.14787793
Const Adj.:	1.03530002
Adj \$ / SQ:	140.231
Other Features:	50500
Grade Factor:	1.00
Neighborhood Inf:	1.00000000
LUC Factor:	1.00
Adj Total:	373522
Depreciation:	117660
Depreciated Total:	255863

COMMENTS**RESIDENTIAL GRID**

1st Res Grid	Desc:	Line 1	# Units	1								
Level	FY	LR	DR	D	K	FR	RR	BR	FB	HB	L	O
Other												
Upper												
Lvl 2												
Lvl 1												
Lower												
Totals	RM:	6	BR:	3	Bath:	3	HB					

REMODELING

Exterior:	
Interior:	
Additions:	
Kitchen:	
Baths:	
Plumbing:	
Electric:	
Heating:	
General:	

RES BREAKDOWN

No Unit	RMS	BRS	FL
1	6	3	
Totals			
1	6	3	

COMPARABLE SALES

Rate	Parcel ID	Typ	Date	Sale Price	
WtAv\$/SQ:		AvRate:		Ind.Val	673430.3822
Juris. Factor:		Before Depr:	140.23		
Special Features:	0	Val/Su Net:	60.84		
Final Total:	255900	Val/Su SzAd	169.69		

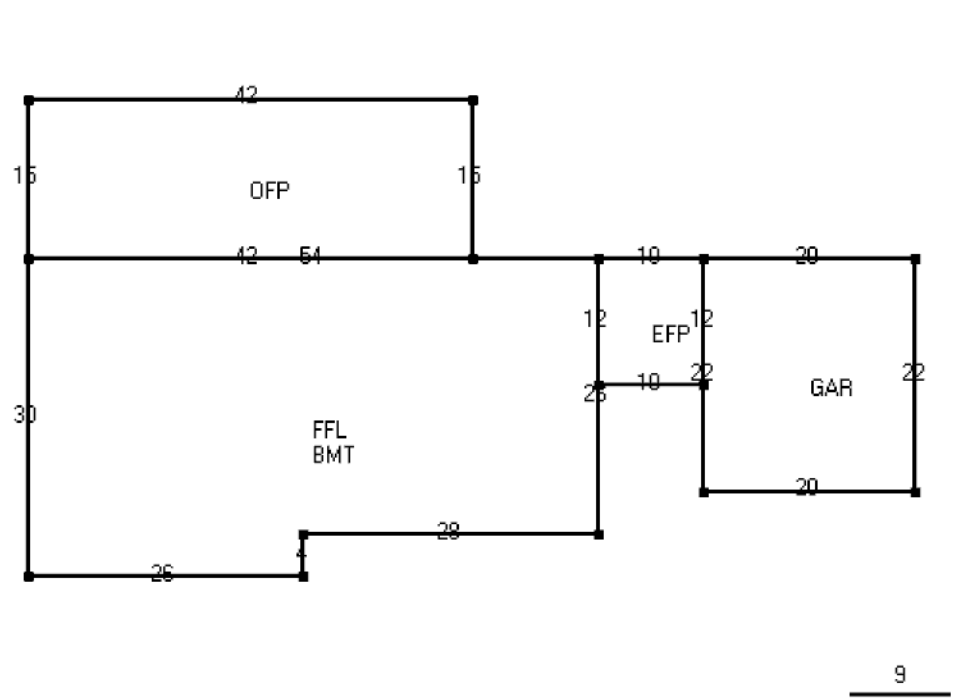
PARCEL ID**SKETCH****SUB AREA**

Code	Description	Area - SQ	Rate - AV	Undepr Value	
BMT	BASEMENT	1,508	54.340	81,944	
FFL	1ST FLOOR	1,508	140.230	211,468	
OPF	OPEN PORCH	630	15.000	9,450	
GAR	GARAGE	440	36.000	15,840	
EFP	ENCL PORCH	120	36.000	4,320	
Net Sketched Area:		4,206	Total:	323,022	
Size Ad	1508	Gross Area	4206	FinArea	2337

SUB AREA DETAIL

Sub Area	% Usbl	Descrip	% Type	Qu	# Ten
BMT	100	RRM	55	A	0

IMAGE**AssessPro** Patriot Properties, Inc