



**PROPERTY LOCATION**

No	Alt No	Direction/Street/City
42		BEDFORD RD, LINCOLN

**OWNERSHIP**

Owner 1:	GERTZ DWIGHT L
Owner 2:	WELLES VIRGINIA C
Owner 3:	
Street 1:	42 BEDFORD RD
Street 2:	
Twn/City:	LINCOLN
St/Prov:	MA Cntry Own Occ: Y
Postal:	01773-2037 Type:

**PREVIOUS OWNER**

Owner 1:	GERTZ - DWIGHT L
Owner 2:	WELLES - VIRGINIA C
Street 1:	42 BEDFORD RD
Twn/City:	LINCOLN
St/Prov:	MA Cntry
Postal:	01773-2037

**NARRATIVE DESCRIPTION**

This Parcel contains 3.27 ACRES of land mainly classified as ONE FAM with a(n) DECK HSE Building Built about 1978, Having Primarily WOOD Exterior and ASPHALT Roof Cover, with 1 Units, 4 Baths, 0 HalfBaths, 0 3/4 Baths, 10 Rooms, and 4 Bdrms.

**OTHER ASSESSMENTS**

Code	Descrip/No	Amount	Com. Int

**PROPERTY FACTORS**

Item	Code	Descp	%	Item	Code	Descp
Z	R1	Residential	100	U	A	SEPTIC
o				t		
n				l		
Census:				Exmpt		
Flood Haz:						
D				Topo		
s				Street	1	PAVED
t				Traffic	4	MEDIUM

**LAND SECTION (First 7 lines only)**

Use Code	Description	LUC Fact	No of Units	Depth / PriceUnits	Unit Type	Land Type	LT Factor	Base Value	Unit Price	Adj	Neigh	Neigh Infl	Neigh Mod	Infl 1	%	Infl 2	%	Infl 3	%	Appraised Value	Alt Class	%	Spec Land	J Code	Fact	Use Value	Notes
101	ONE FAM		80000		SQUARE FE	PRIME SITE		0	10.5	1.000	R5									840,000						840,000	
101	ONE FAM		1.163		ACRES	EXCESS ACRE		0	30,000.	1.000	R5									34,890						34,900	
101	ONE FAM		0.27		ACRES	UNDEV	0.2	0	30,000.	0.200	R5									1,620						1,600	Wetland

**IN PROCESS APPRAISAL SUMMARY**

Use Code	Building Value	Yard Items	Land Size	Land Value	Total Value
101	571,000	500	3.270	876,500	1,448,000
Total Card	571,000	500	3.270	876,500	1,448,000
Total Parcel	571,000	500	3.270	876,500	1,448,000
Source:	Market Adj Cost	Total Value per SQ unit /Card:		360.58	/Parcel: 360.58

Legal Description	User Acct
Entered Lot Size	
Total Land:	
Land Unit Type:	

GIS Ref
GIS Ref
Insp Date
12/07/21

**PREVIOUS ASSESSMENT**

Tax Yr	Use	Cat	Bldg Value	Yrd Items	Land Size	Land Value	Total Value	Asses'd Value	Notes	Date
2022	101	FV	484,100	500	3.27	804,500	1,289,100	1,289,100	Year End Roll	10/19/2021
2021	101	FV	451,900	500	3.27	836,500	1,288,900	1,288,900	Year End Roll	10/15/2020
2020	101	FV	410,800	500	3.27	836,500	1,247,800	1,247,800	Year End Roll	9/26/2019
2019	101	FV	382,100	500	3.27	833,300	1,215,900	1,215,900	Create Final value 2019	6/4/2019
2018	101	FV	382,100	500	3.27	833,300	1,215,900	1,215,900	Year End Roll	9/28/2017
2017	101	FV	382,100	500	3.27	833,300	1,215,900	1,215,900	Year End Roll	9/29/2016
2016	101	FV	378,000	500	3.27	781,300	1,159,800	1,159,800	Year End Roll	1/14/2016
2015	101	FV	361,600	500	3.27	726,100	1,088,200	1,088,200	Year End	10/2/2014

**SALES INFORMATION**

Grantor	Legal Ref	Type	Date	Sale Code	Sale Price	V	Tst	Verif	Assoc PCL Value	Notes
GERTZ,DWIGHT L	65050-137		3/13/2015	CONVENIENC		1	No	No		
GRAY, LESLIE M	26434-256		6/25/1996		720,000	No	No			
GORDON DORIS S	23664-329		9/17/1993		650,000	No	No			

**BUILDING PERMITS**

Date	Number	Descp	Amount	C/O	Last Visit	Fed Code	F. Descp	Comment
3/31/2022	R-22-0062	ROOF	25,000	C				Strip & re-roof 33
9/5/2018	7188	MANUAL	10,477	C	12/10/2018			Install solar hot
12/18/2012	5277	SOLAR PA	36,000	C				install roof mount

**ACTIVITY INFORMATION**

Date	Result	By	Name
12/7/2021	INSPECTED	5	TB
2/16/2017	MEAS/EXT INS	4	JG
7/16/2008	MEAS/EXT INS	25	D ERSKINE
3/2/2001	M&L COMPLETE	613	
5/1/1997	MEAS/EXT INS	600	
10/11/1995	MEAS/EXT INS	607	
6/1/1994	FIELDREV CHG	600	
11/1/1988	INSPECTED	601	

Sign: VERIFICATION OF VISIT NOT DATA

**EXTERIOR INFORMATION**

Type:	20 - DECK HSE
Sty Ht:	1 - 1
(Liv) Units:	1 Total: 1
Foundation:	1 - CONCRETE
Frame:	1 - WOOD
Prime Wall:	26 - WOOD
Sec Wall:	
Roof Struct:	1 - GABLE
Roof Cover:	1 - ASPHALT
Color:	
View / Desir:	

**BATH FEATURES**

Full Bath:	4	Rating:	AVERAGE
A Bath:		Rating:	
3/4 Bath:		Rating:	
A 3QBth:		Rating:	
1/2 Bath:		Rating:	
A HBth:		Rating:	
OthrFix:	2	Rating:	AVERAGE

**COMMENTS**

LONG SETBACK .

**RESIDENTIAL GRID**

1st Res Grid	Desc:	Line 1	# Units	1								
Level	FY	LR	DR	D	K	FR	RR	BR	FB	HB	L	O
Other												
Upper												
Lvl 2												
Lvl 1												
Lower												
Totals	RM	10	BR	4	Bath	4	HB					

**OTHER FEATURES**

Kits:	1	Rating:	AVERAGE
A Kits:		Rating:	
Frpl:	2	Rating:	AVERAGE
WSFlue:		Rating:	

**GENERAL INFORMATION**

Grade:	C+ - AVG. (+)		
Year Blt:	1978	Eff Yr Blt:	
Alt LUC:		Alt %:	
Jurisdict:		Fact:	
Const Mod:			
Lump Sum Adj:			

**CONDO INFORMATION**

Location:	
Total Units:	
Floor:	1 - 1ST FLOOR
% Own:	
Name:	

**REMODELING**

Exterior:	
Interior:	
Additions:	
Kitchen:	
Baths:	
Plumbing:	
Electric:	
Heating:	
General:	
Totals	

**RES BREAKDOWN**

No Unit	RMS	BRS	FL
1	10	4	1
Totals			
1	10	4	

**INTERIOR INFORMATION**

Avg Ht/FL:	STD		
Prim Int Wal:	1 - DRYWALL		
Sec Int Wall:			
Partition:	T - TYPICAL		
Prim Floors:	3 - HARDWOOD		
Sec Floors:			
Bsmnt Flr:			
Bsmnt Gar:	2		
Electric:	3 - TYPICAL		
Insulation:	2 - TYPICAL		
Int vs Ext:	S		
Heat Fuel:	2 - GAS		
Heat Type:	3 - FORCED H/W		
# Heat Sys:	1		
% Heated:	100	% AC:	100
Solar HW:	NO	Central Vac:	NO
% Com Wal:	0	% Sprinkled:	0

**DEPRECIATION**

Phys Cond:	AV - Average	22.%
Functional:		%
Economic:		%
Special:		%
Override:		%
Total:		22.%

**CALC SUMMARY**

Basic \$ / SQ:	124.00
Size Adj.:	0.99193549
Const Adj.:	1.01999998
Adj \$ / SQ:	125.460
Other Features:	65906
Grade Factor:	1.10
Neighborhood Inf:	1.00000000
LUC Factor:	1.00
Adj Total:	732003
Depreciation:	161041
Depreciated Total:	570962

**COMPARABLE SALES**

Rate	Parcel ID	Typ	Date	Sale Price
WtAv\$/SQ:		AvRate:	Ind.Val	1027387.130
Juris. Factor:		Before Depr:	138.01	
Special Features:	0	Val/Su Net:	113.88	
Final Total:	571000	Val/Su SzAd:	230.24	

**SPEC FEATURES/YARD ITEMS**

Code	Description	A	Y/S	Qty	Size/Dim	Qual	Con	Year	Unit Price	D/S	Dep	LUC	Fact	NB Fa	Appr Value	JCod	JFact	Juris. Value
2	SHED/FR	D	Y	1	112		A	AV	1978	15.00	T	70	101					500

**SKETCH**

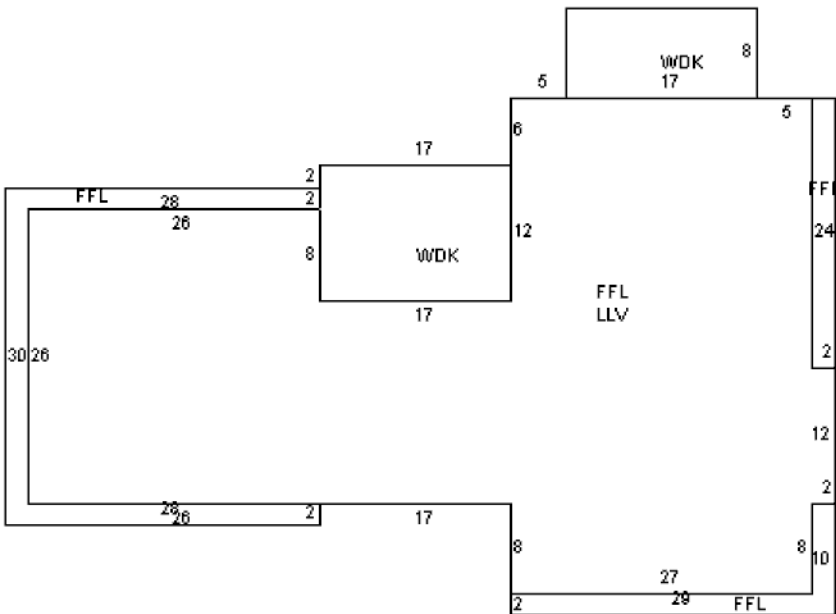

**SUB AREA**

Code	Description	Area - SQ	Rate - AV	Undepr Value	
FFL	1ST FLOOR	2,480	125.460	311,141	
LLV	LOWR LEVEL	2,194	128.600	282,141	
WDK	WOOD DECK	340	18.440	6,270	
Net Sketched Area:		5,014		599,552	
Size Ad	2480	Gross Area	5014	FinArea	4016

**SUB AREA DETAIL**

Sub Area	% Usbl	Descrip	% Type	Qu	# Ten
LLV	100	FLA	70	A	0

**IMAGE**



AssessPro Patriot Properties, Inc

More: N

Total Yard Items: 500

Total Special Features:

Total: 500