

**PROPERTY LOCATION**

No	Alt No	Direction/Street/City
27		CANAAN DR, LINCOLN

**OWNERSHIP**

Owner 1:	BRIEDIS TR JOHN
Owner 2:	BRIEDIS TR IRENE
Owner 3:	IVY REALTY TRUST
Street 1:	27 CANAAN DR
Street 2:	
Twn/City:	LINCOLN
St/Prov:	MA Cntry Own Occ: Y
Postal:	01773 Type:

**PREVIOUS OWNER**

Owner 1:	
Owner 2:	
Street 1:	
Twn/City:	
St/Prov:	Cntry
Postal:	

**NARRATIVE DESCRIPTION**

This Parcel contains 11.2 ACRES of land mainly classified as ONE FAM with a(n) CONTEMPORARY Building Built about 1941, Having Primarily BRICK VENTR Exterior and MEMBRANE Roof Cover, with 2 Units, 3 Baths, 1 HalfBaths, 0 3/4 Baths, 10 Rooms, and 6 Bdrms.

**OTHER ASSESSMENTS**

Code	Descrip/No	Amount	Com. Int

**PROPERTY FACTORS**

Item	Code	Descp	%	Item	Code	Descp
Z	LC	Historic Dst		U	A	SEPTIC
o	R1	Residential	100	t		
n				l		
Census:				Exmpt		
Flood Haz:						
D				Topo		
s				Street	1	PAVED
t				Traffic	4	MEDIUM

**LAND SECTION (First 7 lines only)**

Use Code	Description	LUC Fact	No of Units	Depth / PriceUnits	Unit Type	Land Type	LT Factor	Base Value	Unit Price	Adj	Neigh	Neigh Infl	Neigh Mod	Infl 1	%	Infl 2	%	Infl 3	%	Appraised Value	Alt Class	%	Spec Land	J Code	Fact	Use Value	Notes
101	ONE FAM		80000		SQUARE FE	PRIME SITE		0	12.5	1.000	R6									1,000,000						1,000,000	
101	ONE FAM		6.633		ACRES	EXCESS ACRE		0	30,000.	1.000	R6									198,990						199,000	
101	ONE FAM		2.73		ACRES	UNDEV	0.2	0	30,000.	0.200	R6									16,380						16,400	Unbuildable

**IN PROCESS APPRAISAL SUMMARY**

Use Code	Building Value	Yard Items	Land Size	Land Value	Total Value	Legal Description
101	1,157,700	16,500	11.200	1,215,400	2,389,600	1/8 interest in common land parcels 44-4-0 and 44-4-6
Total Card		1,157,700	16,500	11.200	1,215,400	2,389,600
Total Parcel		1,157,700	16,500	11.200	1,215,400	2,389,600
Source: Market Adj Cost		Total Value per SQ unit /Card: 370.52		/Parcel: 370.52		

**PREVIOUS ASSESSMENT**

Tax Yr	Use	Cat	Bldg Value	Yrd Items	Land Size	Land Value	Total Value	Asses'd Value	Notes	Date
2023	101	FV	998,400	16500	11.2	1,195,400	2,210,300	2,210,300	Year end	11/3/2022
2022	101	FV	868,300	16500	11.2	1,137,000	2,021,800	2,021,800	Year End Roll	10/19/2021
2021	101	FV	824,000	16500	11.2	1,175,400	2,015,900	2,015,900	Year End Roll	10/15/2020
2020	101	FV	810,000	16500	11.2	1,135,400	1,961,900	1,961,900	Year End Roll	9/26/2019
2019	101	FV	826,000	16500	11.2	1,110,600	1,953,100	1,953,100	Create Final value 2019	6/4/2019
2018	101	FV	826,000	16500	11.2	1,110,600	1,953,100	1,953,100	Year End Roll	9/28/2017
2017	101	FV	775,600	16500	11.2	1,110,600	1,902,700	1,902,700	Year End Roll	9/29/2016
2016	101	FV	759,800	16500	11.2	1,084,200	1,860,500	1,860,500	Year End Roll	1/14/2016

**SALES INFORMATION**

Grantor	Legal Ref	Type	Date	Sale Code	Sale Price	V	Tst	Verif	Assoc PCL Value	Notes
BRIEDIS JOHN/IR	23705-22		9/28/1993	FAMILY		No	No			

**BUILDING PERMITS**

Date	Number	Descp	Amount	C/O	Last Visit	Fed Code	F. Descp	Comment
5/12/2022	R-22-0103	ROOF	60,000	C	8/8/2022			Replace approx. 28
5/24/2010	4470	TEMPORAR		C				Tent 6/3 to 6/7
11/12/2003	2814	ROOF		C				garage
10/16/2001	2367	ROOF		C				

**ACTIVITY INFORMATION**

Date	Result	By	Name
9/11/2013	MEAS+INSPCTD	25	D ERSKINE
6/21/2007	MEAS/EXT INS	616	D MANZELLO
11/25/2000	M&L COMPLETE	609	
11/6/1995	MEAS+INSPCTD	607	
11/6/1995	MEAS+INSPCTD	607	
11/6/1995	MEAS+INSPCTD	607	
1/7/1994	INSPECTED	600	
1/24/1992	INSPECTED	601	

Sign: VERIFICATION OF VISIT NOT DATA



**USER DEFINED**

Prior Id # 1:	37 2 0
Prior Id # 2:	
Prior Id # 3:	
Prior Id # 1:	
Prior Id # 2:	
Prior Id # 3:	
Prior Id # 1:	
Prior Id # 2:	
Prior Id # 3:	
ASR Map:	
Fact Dist:	
Reval Dist:	
Year:	
LandReason:	
BldReason:	

EXTERIOR INFORMATION

Table with exterior details including Type: 9 - CONTEMPORARY, Sty Ht: 2 - 2, (Liv) Units: 2 Total: 2, Foundation: 2 - CONC BLOCK, Frame: 1 - WOOD, Prime Wall: 8 - BRICK VENR, Sec Wall: %, Roof Struct: 4 - FLAT, Roof Cover: 11 - MEMBRANE, Color: , View / Desir:

BATH FEATURES

Table with bathroom details including Full Bath: 3 Rating: AVERAGE, A Bath: Rating: , 3/4 Bath: Rating: , A 3QBth: Rating: , 1/2 Bath: 1 Rating: AVERAGE, A HBth: Rating: , OthrFix: 1 Rating: AVERAGE

COMMENTS

SEC 14 ACC APT 1200SF 3 BEDS, LVRM, KIT, BATH.

OTHER FEATURES

Table with other features including Kits: 1 Rating: VERY GOOD, A Kits: 1 Rating: AVERAGE, Frpl: 5 Rating: AVERAGE, WSFlue: Rating:

GENERAL INFORMATION

Table with general info including Grade: A- - V GOOD-, Year Blt: 1941 Eff Yr Blt: , Alt LUC: Alt %: , Jurisdct: Fact: , Const Mod: , Lump Sum Adj:

CONDO INFORMATION

Table with condo info including Location: , Total Units: , Floor: 1 - 1ST FLOOR, % Own: , Name:

RESIDENTIAL GRID

Table with residential grid including 1st Res Grid Desc: Line 1 # Units 1, Level FY LR DR D K FR RR BR FB HB L O, Other Upper, Lvl 2, Lvl 1, Lower, Totals RMs: 10 BRs: 6 Baths: 3 HB 1

REMODELING

Table with remodeling details including Exterior: , Interior: , Additions: 1994, Kitchen: 1995, Baths: , Plumbing: , Electric: , Heating: , General:

RES BREAKDOWN

Table with res breakdown including No Unit RMS BRS FL, Totals 1 10 6

SKETCH

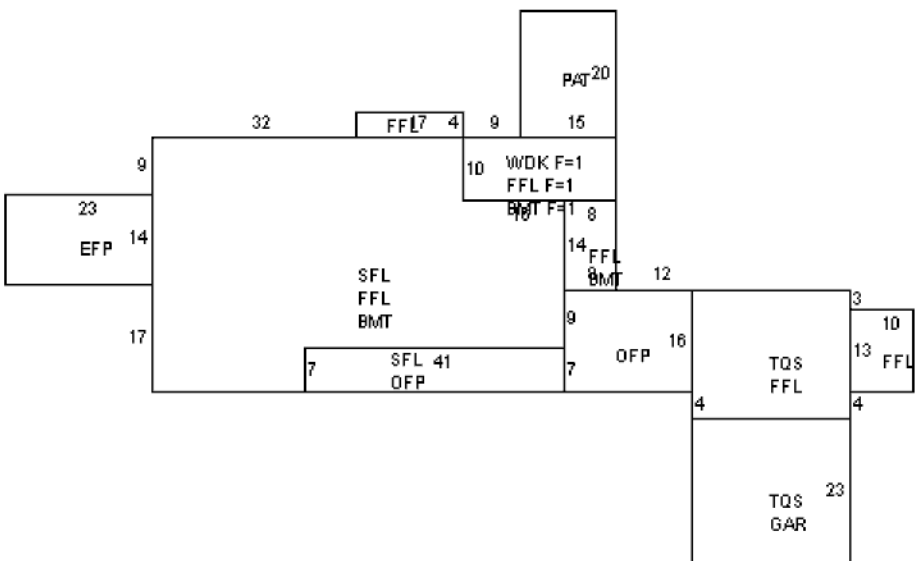

INTERIOR INFORMATION

Table with interior info including Avg Ht/FL: STD, Prim Int Wal: 2 - PLASTER, Sec Int Wall: %, Partition: E - EXTNSIVE, Prim Floors: 3 - HARDWOOD, Sec Floors: %, Bsmnt Flr:

DEPRECIATION

Table with depreciation including Phys Cond: AV - Average 35.%, Functional: %, Economic: %, Special: %, Override: , Total: 35%

CALC SUMMARY

Table with calculation summary including Basic \$ / SQ: 150.00, Size Adj.: 0.84303409, Const Adj.: 1.00727534, Adj \$ / SQ: 127.375, Other Features: 96000, Grade Factor: 1.70, Neighborhood Inf: 1.00000000, LUC Factor: 1.00, Adj Total: 1781064, Depreciation: 623372, Depreciated Total: 1157692

COMPARABLE SALES

Table with comparable sales including Rate Parcel ID Typ Date Sale Price, WtAv\$/SQ: AvRate: Ind.Val 0.00000, Juris. Factor: Before Depr: 216.54, Special Features: 0 Val/Su Net: 105.26, Final Total: 1157700 Val/Su SzAd 179.51

SUB AREA

Table with sub area details including Code Description Area - SQ Rate - AV Undepr Value, Net Sketched Area: 10,998 Total: 951,685, Size Ad 6449.25 Gross Area 11267 FinArea 6449

SUB AREA DETAIL

Table with sub area detail including Sub Area % Usbl Descrip % Type Qu # Ten

SPEC FEATURES/YARD ITEMS

Table with spec features including Code Description A Y/S Qty Size/Dim Qual Con Year Unit Price D/S Dep LUC Fact NB Fa Appr Value JCod JFact Juris. Value

PARCEL ID

135 9 0

More: N Total Yard Items: 16,500 Total Special Features:

Total: 16,500

IMAGE

AssessPro Patriot Properties, Inc

