



Patriot
Properties Inc.

PROPERTY LOCATION

No	Alt No	Direction/Street/City
19		BEDFORD RD, LINCOLN

OWNERSHIP

Owner 1:	WEBSTER ERIC T
Owner 2:	WEBSTER JOSEPH
Owner 3:	
Street 1:	19 BEDFORD RD
Street 2:	
Twn/City:	LINCOLN
St/Prov:	MA Cntry Own Occ: Y
Postal:	01773 Type:

PREVIOUS OWNER

Owner 1:	PONTIN - LAURA
Owner 2:	PONTIN - JOHAN
Street 1:	19 BEDFORD RD
Twn/City:	LINCOLN
St/Prov:	MA Cntry
Postal:	01773

NARRATIVE DESCRIPTION

This Parcel contains 2.4 ACRES of land mainly classified as ONE FAM with a(n) ANTIQUE Building Built about 1844, Having Primarily CLAPBOARD Exterior and ASPHALT Roof Cover, with 1 Units, 4 Baths, 0 HalfBaths, 0 3/4 Baths, 12 Rooms, and 4 Bdrms.

OTHER ASSESSMENTS

Code	Descrip/No	Amount	Com. Int

PROPERTY FACTORS

Item	Code	Descp	%	Item	Code	Descp
Z	LC	Historic Dst		U	A	SEPTIC
o	R1	Residential	100	t		
n				l		
Census:				Exmpt		
Flood Haz:						
D				Topo		
s				Street	1	PAVED
t				Traffic	4	MEDIUM

LAND SECTION (First 7 lines only)

Use Code	Description	LUC Fact	No of Units	Depth / PriceUnits	Unit Type	Land Type	LT Factor	Base Value	Unit Price	Adj	Neigh	Neigh Infl	Neigh Mod	Infl 1	%	Infl 2	%	Infl 3	%	Appraised Value	Alt Class	%	Spec Land	J Code	Fact	Use Value	Notes
101	ONE FAM		80000		SQUARE FE	PRIME SITE		0	10.	1.000	R5									800,000						800,000	
101	ONE FAM		0.193		ACRES	EXCESS ACRE		0	30,000.	1.000	R5									5,790						5,800	
132	UNDEV		0.37		ACRES	CONS RESTR	0.2	0	30,000.	0.200	R5									2,220						2,200	Cons Restr

IN PROCESS APPRAISAL SUMMARY

Use Code	Building Value	Yard Items	Land Size	Land Value	Total Value	Legal Description	User Acct
101	752,900	19,800	2.030	805,800	1,578,500		0
132			0.370	2,200	2,200		GIS Ref
							GIS Ref
Total Card	752,900	19,800	2.400	808,000	1,580,700	Entered Lot Size	
Total Parcel	1,134,300	19,800	2.400	808,000	1,962,100	Total Land: 2.4	
Source:	Market Adj Cost	Total Value per SQ unit /Card: 296.12		/Parcel: 261.82		Land Unit Type:	Insp Date
							10/25/11

PREVIOUS ASSESSMENT

Tax Yr	Use	Cat	Bldg Value	Yrd Items	Land Size	Land Value	Total Value	Asses'd Value	Notes	Date
2020	101	FV	1,119,700	19800	2.4	808,000	1,947,500	1,947,500	Year End Roll	9/26/2019
2019	101	FV	1,919,800	26600	2.4	804,800	2,751,200	2,751,200	Create Final value 2019	6/4/2019
2018	101	FV	1,919,800	26600	2.4	804,800	2,751,200	2,751,200	Year End Roll	9/28/2017
2017	101	FV	1,833,700	26600	2.4	804,800	2,665,100	2,665,100	Year End Roll	9/29/2016
2016	101	FV	1,794,300	26600	2.4	752,800	2,573,700	2,573,700	Year End Roll	1/14/2016
2015	101	FV	1,694,800	26600	2.4	697,600	2,419,000	2,419,000	Year End	10/2/2014
2014	101	FV	1,629,600	26600	2.4	688,000	2,344,200	2,344,200	Year End Roll	1/23/2014
2013	101	FV	1,586,000	26600	2.4	668,000	2,280,600	2,280,600	Year End Roll	10/25/2012

SALES INFORMATION

Grantor	Legal Ref	Type	Date	Sale Code	Sale Price	V	Tst	Verif	Assoc PCL Value	Notes
PONTIN,LAURA	74225-749		3/3/2020		1787500	No	No			
PONTIN,LAURA	55357-36		9/13/2010	FAMILY	100	No	No			
AZRACK JOSEPH F	54748-143		5/28/2010	MULTI-PARCEL	1875000	No	No			
BENJAMIN BRADLE	18294-455		7/6/1987		975000	No	No			

BUILDING PERMITS

Date	Number	Descp	Amount	C/O	Last Visit	Fed Code	F. Descp	Comment
5/1/2020	SH-20-0008	SHEET MT	15,000	O				Sheet metal work t
4/23/2020	R-20-0063	BATH	47,500	O				Retile 2 small bat
4/14/2010	4418	ROOF		C				replace old roof w
1/17/2006	3343	DEMOLITI		C				dem tennis court a
10/7/2003	2788	ROOF		C				
7/3/2000	2020	RENOVATI	50,000	C	5/25/2001			carriage house
3/9/2000	1884	ROOF	3,000	C	5/29/2000			5/29/00 100%
2/26/1998	1345	ADDITION	60,000	C	6/2/1998			add new sunroom 10
2/26/1998	1344	DEMOLITI		C	6/2/1998			demolish sunroom 1
5/24/1996	957-96	MANUAL	45,000	C	6/23/1997			MST BATH

ACTIVITY INFORMATION

Date	Result	By	Name
10/25/2011	MEAS/EXT INS	25	D ERSKINE
6/29/2006	MEAS/EXT INS	50	
11/2/2002	M&L EXTERIOR	615	
5/25/2001	MEAS+INSPCTD	615	
2/9/2001	M&L COMPLETE	610	
5/29/2000	MEAS/EXT INS	611	
6/2/1998	MEAS/EXT INS	602	
6/23/1997	MEAS+INSPCTD	602	
10/13/1995	ENTRY DENIED	606	

Sign: VERIFICATION OF VISIT NOT DATA

EXTERIOR INFORMATION

Type:	1 - ANTIQUE
Sty Ht:	2A - 2A
(Liv) Units:	1 Total: 2
Foundation:	3 - BRK OR STN
Frame:	1 - WOOD
Prime Wall:	2 - CLAPBOARD
Sec Wall:	
Roof Struct:	1 - GABLE
Roof Cover:	1 - ASPHALT
Color:	
View / Desir:	

BATH FEATURES

Full Bath:	4	Rating:	GOOD
A Bath:		Rating:	
3/4 Bath:		Rating:	
A 3QBth:		Rating:	
1/2 Bath:		Rating:	
A HBth:		Rating:	
OthrFix:	3	Rating:	GOOD

COMMENTS

Also owns 53-12 4 (0.37 ac).

GENERAL INFORMATION

Grade:	B+ - GOOD (+)		
Year Blt:	1844	Eff Yr Blt:	
Alt LUC:		Alt %:	
Jurisdct:		Fact.:	
Const Mod:			
Lump Sum Adj:			

OTHER FEATURES

Kits:	1	Rating:	GOOD
A Kits:		Rating:	
Frpl:	2	Rating:	AVERAGE
WSFlue:		Rating:	

CONDO INFORMATION

Location:	
Total Units:	
Floor:	1 - 1ST FLOOR
% Own:	
Name:	

RESIDENTIAL GRID

1st Res Grid	Desc:	Line 1	# Units	1								
Level	FY	LR	DR	D	K	FR	RR	BR	FB	HB	L	O
Other												
Upper												
Lvl 2												
Lvl 1												
Lower												
Totals	RMs:	12	BRs:	4	Baths:	4	HB					

REMODELING

Exterior:	
Interior:	
Additions:	
Kitchen:	
Baths:	
Plumbing:	
Electric:	
Heating:	
General:	

RES BREAKDOWN

No Unit	RMS	BRS	FL
1	12	4	
Totals			
1	12	4	

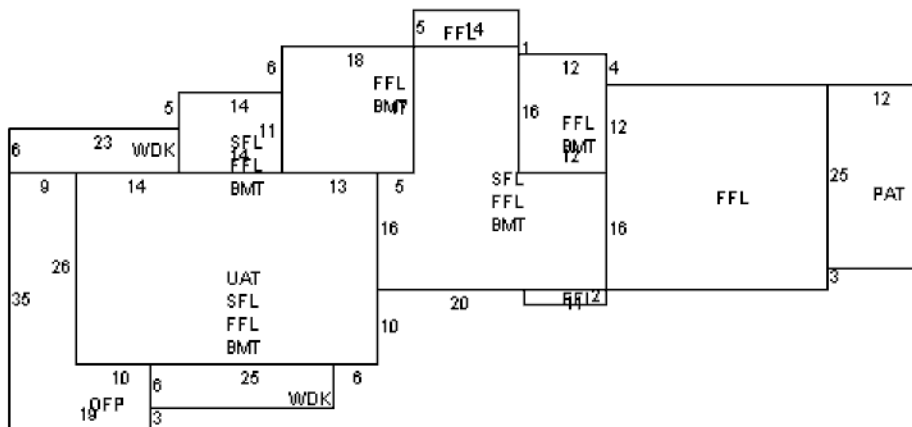
SKETCH

INTERIOR INFORMATION

Avg Ht/FL:	STD
Prim Int Wal:	2 - PLASTER
Sec Int Wall:	
Partition:	E - EXTNSIVE
Prim Floors:	3 - HARDWOOD
Sec Floors:	
Bsmnt Flr:	
Bsmnt Gar:	

DEPRECIATION

Phys Cond:	GD - Good	26.0%
Functional:		
Economic:		
Special:		
Override:		
Total:		26%

CALC SUMMARY

Basic \$ / SQ:	100.00
Size Adj.:	0.86240166
Const Adj.:	1.00979996
Adj \$ / SQ:	87.085
Other Features:	90000
Grade Factor:	1.60
Neighborhood Inf:	1.0000000
LUC Factor:	1.00
Adj Total:	1017398
Depreciation:	264523
Depreciated Total:	752875

COMPARABLE SALES

Rate	Parcel ID	Typ	Date	Sale Price
WtAv\$/SQ:		AvRate:		Ind.Val 2243400.000
Juris. Factor:		Val/Su Fin:	141.05	
Special Features:	0	Val/Su Net:	84.19	
Final Total:	752900	Val/Su SzAd:	141.05	

SUB AREA

Code	Description	Area - SQ	Rate - AV	Undepr Value	
FFL	1ST FLOOR	3,384	87.090	294,697	
BMT	BASEMENT	2,452	21.770	53,383	
SFL	2ND FLOOR	1,954	87.090	170,165	
OPF	OPEN PORCH	405	15.000	6,075	
PAT	PATIO	300	7.000	2,100	
WDK	WOOD DECK	288	19.200	5,529	
UAT	UNF ATTIC	160	87.090	13,925	
Net Sketched Area:		8,943	Total:	545,874	
Size Ad	5338	Gross Area	9849	FinArea	5338

SUB AREA DETAIL

Sub Area	% Usbl	Descrip	% Type	Qu	# Ten

SPEC FEATURES/YARD ITEMS

Code	Description	A	Y/S	Qty	Size/Dim	Qual	Con	Year	Unit Price	D/S	Dep	LUC	Fact	NB Fa	Appr Value	JCod	JFact	Juris. Value
3	GARAGE	D	Y	1	24x28	A	GD	1910	36.00	T	40	101			14,500			14,500
12	POOL I-G	D	Y	1	800	A	AV	1970	22.00	T	70	101			5,300			5,300

PARCEL ID 144 3 0

More: N

Total Yard Items: 19,800

Total Special Features:

Total: 19,800

IMAGE

AssessPro Patriot Properties, Inc

